

ANAFI Ai

FreeFlight 7 User Guide

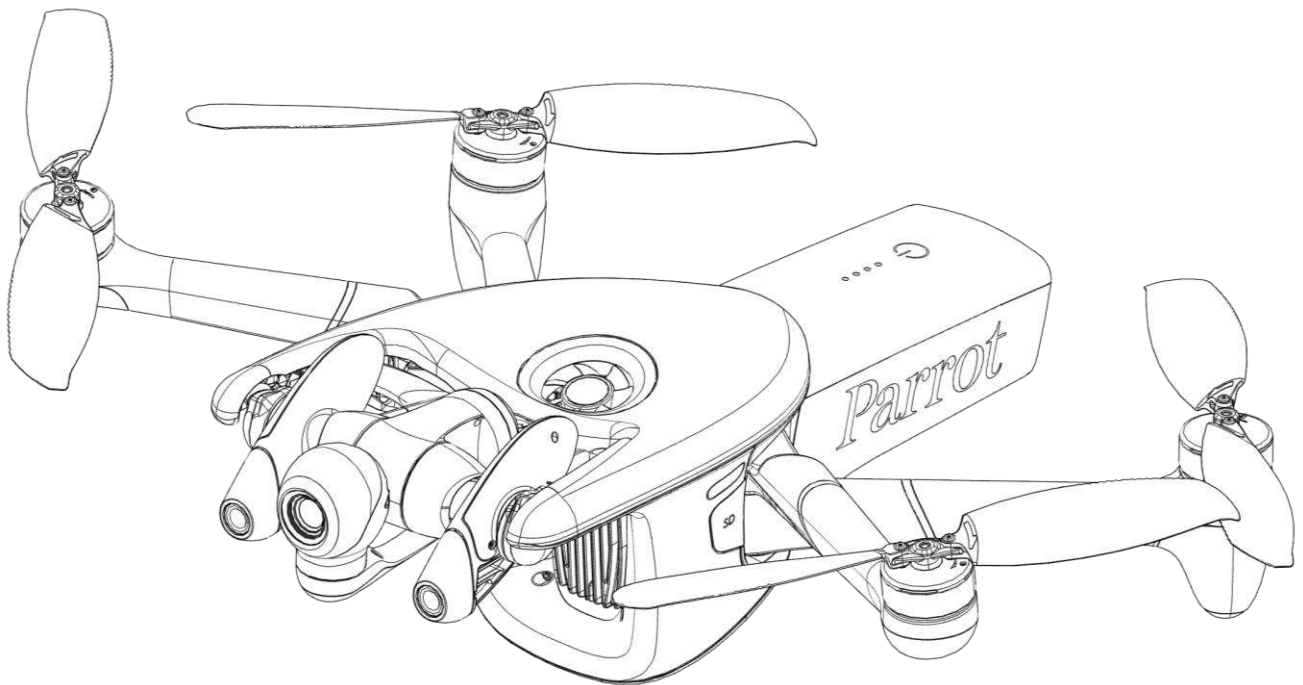

Version: 7.7.1.2

Updated: April, 4th, 2024

Parrot

Documentation changelog

This section details the major changes to Parrot's technical documentation since the previous update.

| What changed | Where |
|---|------------------|
| Images updated | Throughout guide |
| Technical specifications chapter updated | Page 11 |
| MicroSD card and media management chapter updated | Page 45 |
| Videos, photos, and panoramas chapter updated | Page 55 |

Using this guide

Parrot recommends that you read the following user guide thoroughly before your first flight. This user guide completes the ANAFI Ai documentation, which also includes the:

- ANAFI Ai [Flight Safety Guide](#);
- ANAFI Ai and FreeFlight 7 [release notes](#);
- ANAFI Ai [Video Tutorials](#).

Read the Flight Safety Guide provided with the ANAFI Ai to have complementary information about safety, operational limitations for use and maintenance of the drone. Always verify that you are using the latest version of the [User Guide](#).

This guide is specific to a single drone configuration, consisting of:

- The ANAFI Ai drone.
- The Parrot Skycontroller 4.
- The FreeFlight 7 flight application.

NOTE: ANAFI Ai requires the FreeFlight 7 app to fly, and to ensure that the drone and controller are fully up to date with the latest features.

All future ecosystem updates (app, drone, controller) will be packed in future FreeFlight 7 releases. The ecosystem update procedure will therefore always be the same as that described in the following pages.

- **Read entirely at least once.** It answers most questions that most users may encounter when they use ANAFI Ai.
- **Keep it for reference and stay alert for updates.** Updates are advertised on all Parrot websites and social media. These updates are mandatory and must be systematically performed prior to any flight to ensure maximum performance and safety.
- **The Table of contents, starting on page 6, is active.** Click a title to access the corresponding section.
- **This online user guide has no index.** the keyboard shortcut **Ctrl + F** (Windows) or **Command + F** (Mac) to browse all occurrences of any keyword (*flight, settings, photogrammetry, obstacle avoidance, gimbal, iPhone, photo, ISO, etc*).

IMPORTANT: Parrot strongly recommends that you regularly refer to the [Release Notes ANAFI Ai](#) available on the Parrot website, to ensure that you have the latest versions of the drone and controller firmware, and FreeFlight 7 App.

Prerequisites

Refer to the enclosed Super Quick Start Guide (SQSG) if you require illustrated guidance for the prerequisites.

1. Wake up the ANAFI Ai's smart battery. Charge the battery using the enclosed USB-C to USB-C cables and the enclosed charger. The battery's LEDs start to flash indicating that the battery is awake. Let it charge. Parrot recommends you always run a full charge of the smart battery, and the Skycontroller 4 before flying ANAFI Ai.
2. Scan the following QR code to download the latest version of FreeFlight 7 to your iOS device. ANAFI Ai requires FreeFlight 7 to fly. The app enables you to update the Parrot Skycontroller 4 and ANAFI Ai with the latest software version when you power them on for the first time.



iOS FreeFlight 7 QR code

The fully secure piloting software of ANAFI Ai, FreeFlight 7, guarantees the integrity of data exchanges for the full ecosystem, and manages updates (piloting software, drone, remote control).

3. When the download and installation of FreeFlight 7 is complete, turn on the Skycontroller 4. Press and hold Skycontroller 4's **Power** button for approximately 3 seconds to power it on. The main LED turns light blue.
4. On ANAFI Ai, remove the gimbal's protective cover. Press the **Push** label on the cover with your thumb and position a finger on each side, and lift the cover off.
5. Press and hold ANAFI Ai's **Power** button for approximately 3 seconds to power it on. The drone's fan starts to turn.

CAUTION: During the first boot, the battery updates automatically to the firmware version on the drone. Do not remove the battery from the drone while the LEDs are flashing.

6. Use the enclosed USB-C to Lightning cable to connect your device to the right-side USB-C port of the Skycontroller 4 and install your device on the controller as shown in the enclosed SQSG.

A prompt appears on your screen, which invites you to allow communication between your device and the controller.

7. Tap **Allow** to run FreeFlight 7.

NOTE: If the prompt does not appear on your screen when you connect your device to your Skycontroller, tap the app logo on your device's screen to launch FreeFlight 7 manually.

IMPORTANT: You must update the drone and controller before taking off.

8. Tap **Update** and follow the onscreen instructions to update your ecosystem. Begin with the controller update.
9. Skycontroller 4 update: tap **Software**.

A circular green progress bar indicates that the update is under way. This operation takes a few minutes.

10. Proceed to the drone update. Tap **Software** on the ANAFI Ai page to launch the update.
11. Tap **Install all**.
12. Tap **Ok** when the update is complete.

Follow the onscreen instructions to perform calibrations if required. Refer to the "[Calibrations](#)" section for more information.

All systems are ready for flight.

Table of contents

| | | | |
|---|-----------|--|-----------|
| Documentation changelog | 2 | Calibrations | 28 |
| Using this guide | 3 | Skycontroller 4 calibration | 28 |
| Prerequisites | 4 | Gimbal calibration..... | 29 |
| Table of contents | 6 | Correct horizon calibration (exceptional procedure)..... | 29 |
| Foreword | 8 | Magnetometer calibration..... | 30 |
| ANAFI Ai ecosystem | 8 | Obstacle avoidance calibration..... | 30 |
| Overhead power lines and pylons..... | 8 | Pre-flight checklist | 32 |
| Radiation Fields | 8 | Transport & handling | 32 |
| Wi-Fi | 8 | Equipment | 32 |
| GPS | 8 | Regulations | 32 |
| 4K video formats | 9 | Flight conditions | 32 |
| Audio recording..... | 9 | Getting started | 33 |
| ANAFI Ai smart batteries..... | 9 | Taking off | 34 |
| HDMI | 9 | Ground take-off | 34 |
| Auto-RTH (Return to Home)..... | 9 | Hand launch..... | 34 |
| Parrot.Cloud accounts..... | 9 | Flying | 36 |
| Information related to Privacy Rights | 9 | Returning home: Smart RTH | 37 |
| Disclaimer | 10 | Low battery Smart RTH | 37 |
| Technical specifications | 11 | Ecosystem link loss Smart RTH..... | 37 |
| Package contents | 13 | Pilot Smart RTH..... | 38 |
| Presentation of ANAFI Ai | 14 | Landing | 39 |
| LEDs and assistance lights | 15 | Hand landing..... | 39 |
| Turn off ANAFI Ai..... | 15 | Smart LiPo Battery | 41 |
| Presentation of Skycontroller 4 | 16 | Battery removal | 41 |
| LED Status indicator color codes | 18 | Battery installation | 41 |
| Pairing ANAFI Ai to a Skycontroller 4 | 18 | Battery charging..... | 41 |
| HDMI video sharing..... | 18 | Battery care and safety | 42 |
| GPS receiver compatibility | 19 | Battery state of health..... | 43 |
| 4G Connectivity | 20 | Battery update | 44 |
| Installing and retrieving the nano SIM card | 20 | MicroSD card and media management | 45 |
| Activating the nano SIM card | 21 | Installing a microSD card..... | 45 |
| Data sharing and User accounts | 23 | Retrieving photos and videos | 45 |
| Anonymous sharing (default option) | 23 | Compatible microSD cards..... | 45 |
| Private mode (zero data)..... | 24 | Direct media retrieval (drone to computer) | 45 |
| Parrot.Cloud account & Full sharing..... | 24 | FreeFlight 7 Medias gallery..... | 46 |
| PIX4D account | 25 | Introducing FreeFlight 7 | 47 |
| Obstacle avoidance | 26 | Presentation of the HUD..... | 47 |
| Obstacle avoidance and manual piloting | 26 | HUD Slider Management | 48 |
| Obstacle avoidance and automated flights..... | 27 | Settings | 49 |
| | | Quick..... | 49 |

| | | | |
|--|-----------|--|-----------|
| Controls | 49 | Missions: Flight Plan | 73 |
| Advanced..... | 49 | Missions: Cameraman..... | 77 |
| Videos, Photos, and Panoramas | 55 | Missions: Vehicle | 79 |
| Making videos | 55 | Missions: Touch & Fly | 84 |
| Taking photos..... | 56 | Flight logs and projects management | 88 |
| Creating Panoramas | 57 | Flight logs..... | 88 |
| Media Metadata..... | 59 | Projects | 89 |
| Gimbal tilt control | 60 | Maintenance and Troubleshooting..... | 91 |
| Zoom control..... | 60 | Changing propeller blades | 91 |
| Advanced image settings | 62 | Rebooting all systems | 91 |
| Lock AE | 62 | Reinstalling FreeFlight 7..... | 92 |
| Shutter speed (s) | 64 | ANAFI Ai drone hard reset | 92 |
| ISO value (ISO)..... | 64 | Resetting the Skycontroller 4..... | 92 |
| Exposure value (EV)..... | 64 | ANAFI Ai’s smart battery hard reset | 93 |
| White balance (WB) | 65 | Recover ANAFI Ai | 93 |
| HDR | 67 | 4G connectivity issues..... | 94 |
| Missions..... | 69 | Drone end of service life | 95 |
| Missions: Piloting | 69 | Appendix 1: Operational Checklist..... | 96 |
| Missions: Photogrammetry | 69 | | |

Foreword

ANAFI Ai was designed and optimized to fly as is. Parrot strongly discourages the use of any add-on or accessory which could be mounted on, or attached to ANAFI Ai (feet extensions, buoys, hulls, etc.). Accessories impose extra weight on the drone and its motors. Electronic accessories may also interfere with the drones' communications.

IMPORTANT: The maximum take-off mass (MTOM) of ANAFI Ai is 1,170 g (2.58 lb). If you equip your drone with an accessory, it can drastically reduce its autonomy.

CAUTION: Do not alter the center of gravity of the drone.

Always transport ANAFI Ai safely stored in its case. Always reposition the gimbal protective cover before storing the drone in its case.

ANAFI Ai ecosystem

In the following pages, the word "*ecosystem*" refers to the drone (ANAFI Ai), its controller (Skycontroller 4) and the FreeFlight 7 flying app. The word "*device*" refers to the iOS smartphone or tablet on which FreeFlight 7 is installed.

Overhead power lines and pylons

Flying close to power installations may impact the behavior of the drone. Higher voltage and/or current creates higher electromagnetic interference, which can affect the drones' communications.

CAUTION: Do not fly within 3 m (9 ft) of a power installation.

Radiation Fields

The proximity of high intensity radiation field may impact the behavior of the drone, for example, airport radar.

CAUTION: Do not fly within:

- 500m of a high intensity radar beam.
- 50m of a radar installation.

Wi-Fi

Parrot recommends that you switch off your device's Wi-Fi connection when flying ANAFI Ai with both the Parrot Skycontroller 4 and your device. When the device's Wi-Fi is switched off, the drone and the controller communicate through ANAFI Ai's Wi-Fi network. Activating your device's Wi-Fi may result in interference.

Your device's Wi-Fi must only be activated, and connected to ANAFI Ai's Wi-Fi network, when you want to fly the drone using your device as the sole controller.

GPS

ANAFI Ai does not require a satellite synchronization, or fix, to take off (for example, GPS, GLONASS, Galileo). It can therefore be piloted indoors and through cluttered areas, stabilized by its onboard sensors.

However, automated and assisted flight modes require both ANAFI Ai and the FreeFlight 7 device synchronization to geocoordinate satellites. The Skycontroller 4 alone has no geo-positioning capacity.

Parrot recommends ANAFI Ai pilots to always set up, start, and finish their automated and assisted flights from wide open areas, such as a sports field.

4K video formats

4K video formats are professional grade media which may not be read natively by slower computers. If the media do not read properly on your equipment, shoot in 1080p or use a video converter to turn your ANAFI Ai's 4K videos into a more manageable format, such as 1080p.

Audio recording

ANAFI Ai is equipped with a microphone to record videos with sound. The drone's microphone can be activated or deactivated through the **Audio** item of the Quick settings menu of FreeFlight 7. Refer to the "[Settings / Quick](#)" section for more information.

ANAFI Ai smart batteries

One smart battery comes preinstalled on ANAFI Ai. If you remove the battery, you must reinstall it in the same orientation.

IMPORTANT: The LEDs and power button face up in the correct orientation

NOTE: ANAFI Ai and Skycontroller 4 batteries enter a **Wintering mode** when not in use for ten consecutive days. You must wake the batteries up and charge them completely before you fly ANAFI Ai for the first time.

HDMI

The Skycontroller 4 is equipped with a micro-HDMI port, which enables you to stream ANAFI Ai images to a screen or to HDMI goggles. Parrot recommends using a certified micro-HDMI to HDMI cable (not included in the box) to connect external pieces of equipment to the Skycontroller 4. Uncertified cables may impair the ecosystem's Wi-Fi performance. Certified HDMI cable packaging displays the following logo:



Auto-RTH (Return to Home)

If the battery charge level becomes low, ANAFI Ai attempts to return to its most recent take-off point, at a minimal height over this take-off point. The default minimal height is 50 meters, but you can configure this height to between 20 and 100 meters through FreeFlight 7.

IMPORTANT: This feature requires synchronization to GPS, GLONASS, or Galileo satellites.

Refer to the "[Returning home: Smart RTH](#)" and "[Settings / Advanced / RTH](#)" sections of this guide for more information on RTH.

Parrot.Cloud accounts

Parrot strongly recommends that you use your Parrot.Cloud account (or create one if ANAFI Ai is your first Parrot drone) to allow Parrot to store your ANAFI Ai flight data. Sharing your data, even anonymously, benefits the community, as it enables us to improve our products. It also directly benefits all identifiable users in case they need to contact Parrot support teams.

Refer to the "[Data sharing and user accounts / Parrot.Cloud account & Full sharing](#)" section for more information.

Information related to Privacy Rights

For more information about the appearance of individuals in videos and photos taken by a drone, refer to the Flight Safety Guide included in the ANAFI Ai packaging.

Disclaimer

1. ANAFI Ai IS NOT A TOY and must not be used or handled by persons under the age of 18 years.
2. BEFORE USING ANAFI Ai:
 - (A) CAREFULLY READ the user manual and all information and documentation available on www.parrot.com. Documentation is subject to change and may be updated at any time and without prior notice (hereinafter referred to as "Parrot Documentation"). SPECIAL ATTENTION must be given to the paragraphs marked: **WARNING, CAUTION, IMPORTANT**.
 - (B) Ensure that the complete drone ecosystem is up-to-date. Parrot regularly releases firmware updates for:
 - FreeFlight 7
 - ANAFI Ai
 - Smart Battery
 - Skycontroller 4

Updates add new features, and improve stability, and performance of the complete system. Updates are mandatory and must be systematically performed prior to any flight to ensure maximum performance and safety. Flying with a non-up-to-date system may impact warranty rights and jeopardize safety requirements.

- (C) ENSURE YOU ARE AWARE OF THE REGULATIONS APPLICABLE TO THE USE OF DRONES AND THEIR ACCESSORIES (hereinafter referred to as "Applicable Regulations");
 - (D) REMEMBER that ANAFI Ai may expose others and yourself to EQUIPMENT DAMAGE, PERSONAL INJURY, OR BOTH, which could result in serious harm or death.
3. All Parrot drones must always be used with genuine Parrot smart batteries. Non-genuine batteries are forbidden, and their use will void the warranty, and impact safety requirements.
4. All Parrot drone systems include charger(s). These are the only recommended chargers to use to charge your Parrot drones Smart Battery and Skycontroller 4. Other generic USB chargers may be used provided that they are certified according to the country of use and have the applicable rating/specification. Performance and warranty are only guaranteed when using a genuine charger included in the Parrot drone system. Parrot takes no responsibility (warranty or safety) for third party USB chargers being used with a Parrot system.
5. Videos and photos promoted and advertised by Parrot Drones SAS and its affiliates have been made by and with experienced professionals and drone pilots. IN CASE OF DOUBT RELATING TO THE USE OF YOUR ANAFI Ai DRONE AND ITS ACCESSORIES, ALWAYS REFER TO THE MOST RECENT VERSION OF THE PARROT DOCUMENTATION.
6. TO THE MAXIMUM EXTENT PERMITTED BY APPLICABLE LAW, PARROT DRONES SAS, ITS SUBSIDIARIES, AND THEIR RESPECTIVE DISTRIBUTORS AND RETAILERS SHALL NOT BE LIABLE FOR ANY DAMAGES ARISING FROM, OR IN CONNECTION WITH NON-COMPLIANCE OF PARROT DOCUMENTATION OR THE APPLICABLE REGULATIONS BY YOURSELF OR ANY PERSON USING YOUR ANAFI Ai.

IMPORTANT: Parrot strongly recommends that you regularly refer to the [Release Notes ANAFI Ai](#) available on the Parrot website, to ensure that you have the latest firmware versions of the drone, controller, application.

Technical specifications

DRONE

- Size folded: 304 x 130 x 118 mm (11.9 x 5.1 x 4.6")
- Size unfolded: 320 x 440 x 118 mm (12.6 x 17.3 x 4.6")
- Mass: 898 g (1.98 lb)
- Maximum take-off mass (MTOM): 1,170 g (2.58 lb)
- Ready to fly in 60 seconds
- Maximum transmission range with the enclosed Skycontroller 4:
 - Wi-Fi: 4 km (2.49 mi)
 - 4G: Unlimited (Provided there is 4G coverage)
- Maximum flight time: 32 minutes
- Maximum horizontal speed: 17 m/s (38.1 MPH)
- Maximum ascent speed: 4 m/s (8.9 MPH)
- Maximum descent speed: 4 m/s (8.9 MPH)
- Maximum wind resistance:
 - During flight: 14 m/s (31.3 MPH)
 - During take-off and landing: 12 m/s (26.8 MPH)
- Maximum propeller speed: 12,000 RPM
- Sound power level: 81 dBA
- Service Ceiling: 5,000 m above MSL (Mean Sea Level)
- User defined geofencing
- Operating temperatures: -10 °C to 40 °C (14 °F to 104 °F)
- IP53: Rain and dust resistant
- Maximum static thrust: 23.27 N
- Thrust to weight ratio: 2.65
- MicroSD and nano SIM card slots
- Takes off from / lands in the hand of the operator
- Indoor flight

SENSORS

- Satellite navigation: GPS, GLONASS, and Galileo
- Barometer and magnetometer
- Vertical camera and Time of Flight
- 2 x 6-axis inertial measurement units (flight and camera)
- 2 x 3-axis accelerometers
- 2 x 3-axis gyroscopes
- Stereoscopic cameras mounted on a 311° rotating gimbal (-107° to +204°) for obstacle avoidance
- AI trajectory optimization system

CYBERSECURITY

- Zero data shared without user consent
- FIPS140-2 compliant and CC EAL5+ certified
- Secure Elements Strong authentication for 4G
- Digitally signed pictures
- Transparency & Bug bounty continuous security check

CONNECTIVITY

- Seamless 4G / Wi-Fi switching
- Flies Beyond Visual Line of Sight
- 1080p 30 fps live streaming
- No interference near telecom towers

AUTONOMOUS FLIGHT

- Photogrammetry: grid, double grid, circular, 1-click
- Flight Plan: multiple Waypoints and Points of Interest
- Cameraman: automatic framing with visual tracking
- Smart RTH: customizable return altitude
- Vehicle: flight adapted to controller location reference

EO IMAGE CHAIN

- Sensor: 1/2" 48 MP CMOS
- Digital zoom: 6x – lossless: up to 4x (1080p) & 2x (4K UHD)
- Electronic shutter speed: 1 s to 1/10,000 s
- ISO range: 50 to 6,400
- Video resolution: 4k/UHD/HD
- Video format: MP4 (H.264, H.265)
- Photo resolution:
 - Wide: 48 MP (73.0° HFOV)
 - Rectilinear: 48 MP (up to 69.0° HFOV without EIS)
- Photo formats: 48 MP (up to 69.0° HFOV without EIS)
- Dynamic range: 14 EV in HDR mode
- Optical LD-ASPH (low dispersion aspheric lens)
- Aperture: f/2.0
- 35 mm focal equivalent: 24 mm
- Depth of field: 4.5 m to ∞
- 6-axis stabilization

IMAGE STABILIZATION

- Stabilized gimbal:
 - Hybrid: 3-axis
 - Mechanical: 3-axis yaw / roll / pitch
 - Electronic (EIS): 3-axis yaw / roll / pitch
- Controllable gimbal tilt range: -90° to +90°

FAST-CHARGING SMART BATTERY

- Type: High Density LiPo (214 Wh/kg)
- Capacity: 6,800 mAh
- Voltage (nominal): 11.55 V (3 x 3.85 V cells)
- Battery life: 32 minutes
- Charging port: USB-C
- Charges fully in 2 h 30 mins with the included USB-PD (Power Delivery) charger
- Mass: 366 g (0.81 lb)
- Maximum charging power: 45 W

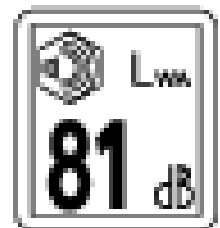

SKYCONTROLLER 4

- Minimum size (without device): 238 x 147 x 55 mm (9.4 x 5.8 x 2.2")
- Maximum size: 315 x 147 x 55 mm (12.4 x 5.8 x 2.2")
- Mass: 610 g (1.35 lb)
- Transmission system: Wi-Fi 802.11a/b/g/n (Wi-Fi beacon)
- Operating frequencies: 2.4 GHz, UNII-1, & UNII-3
- Direct video stream resolution: 1080p
- Battery capacity: 3,350 mAh
- Battery voltage (nominal): 7.2 V
- Battery life: Charges fully in 3 h 45 mins for up to 6 h use (varies according to device used and state of charge)
- Compatible mobile devices: Screen size up to 8"
- Charges smartphones and tablets
- USB ports: 2 x USB-C (charging and connecting)
- Micro-HDMI port
- IP5X: Dust resistant

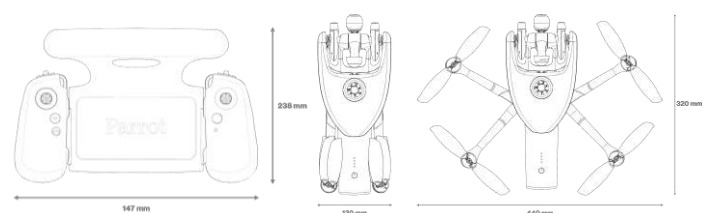

CENTER OF GRAVITY

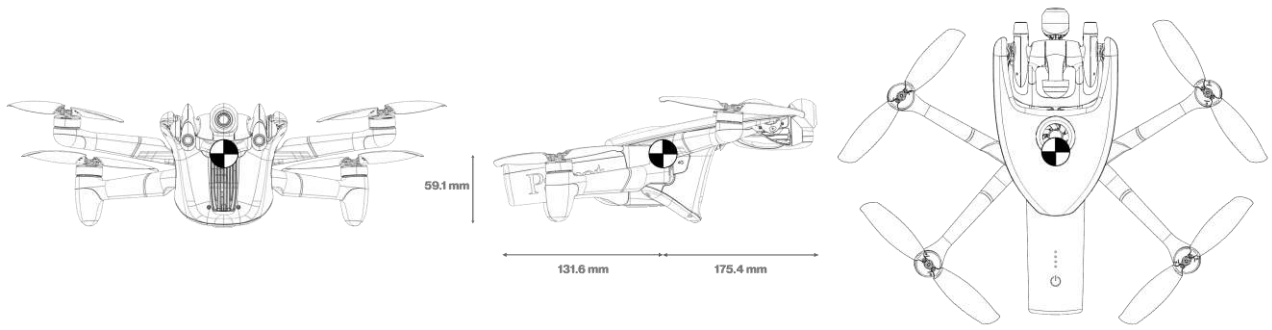

Package contents

Your ANAFI Ai pack contains:

- 1 ANAFI Ai drone
- 1 Skycontroller 4
- 1 smart battery, preinstalled on ANAFI Ai
- 1 worldwide compatible USB-PD fast charger
- 1 additional set of propeller blades
- 2 long USB-C to USB-C cables for charging and pairing
- 2 short USB cables (1 Lightning and 1 USB-C) to connect devices
- 1 additional set of joysticks
- 1 gimbal protection cover
- A Flight Safety Guide
- 1 hard case



Presentation of ANAFI Ai

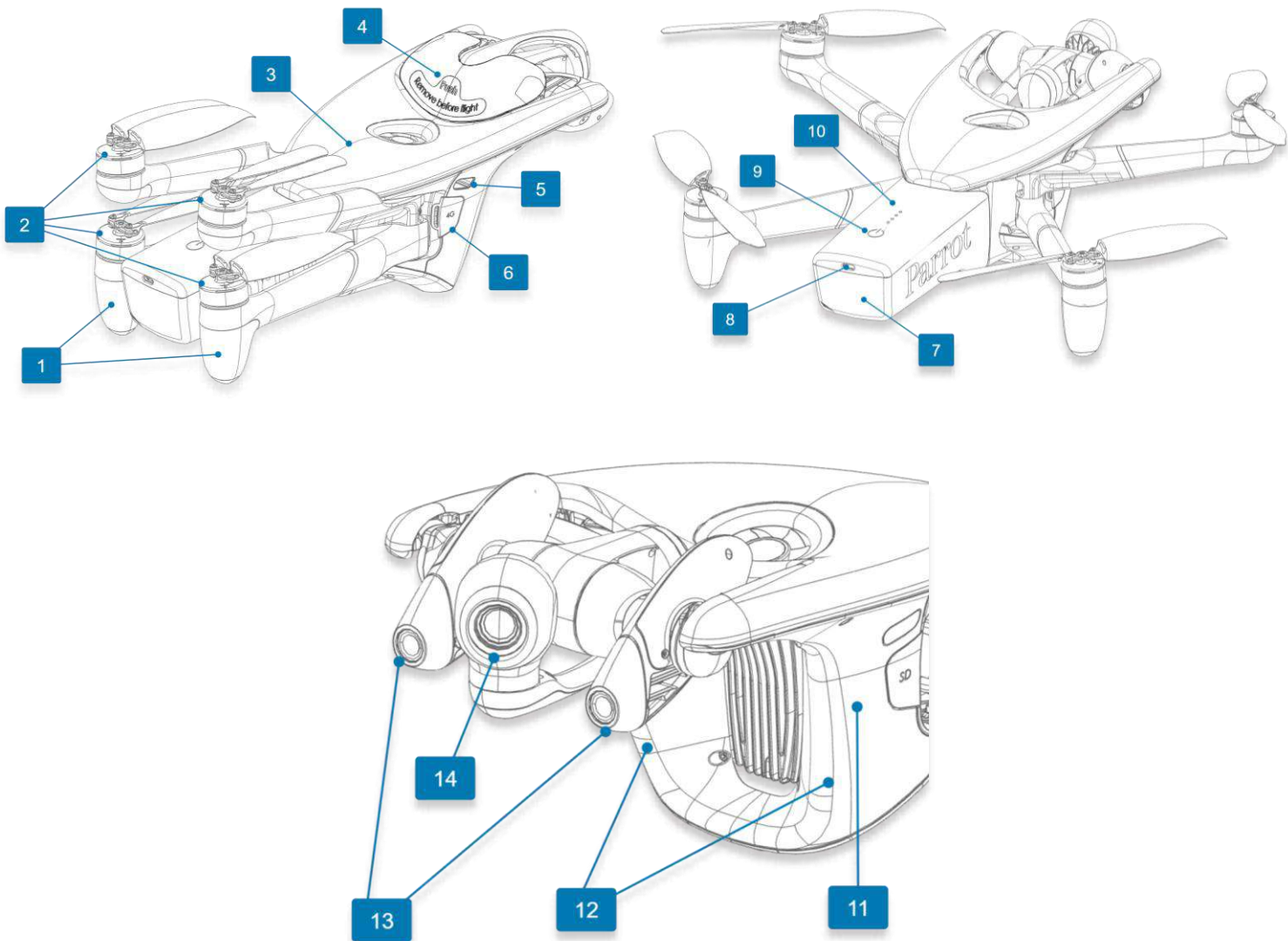

1. Rear Wi-Fi antennas
2. Foldable arms and propellers
3. GNSS antenna
4. Gimbal protective cover
5. Right LED
6. 4G Cover
7. Smart battery
8. USB-C charging port
9.  **Power**
10. Charge level LED indicators
11. Main 4G antenna
12. Front Wi-Fi antennas
13. Stereo obstacle avoidance cameras
14. 180° tilt 4K camera

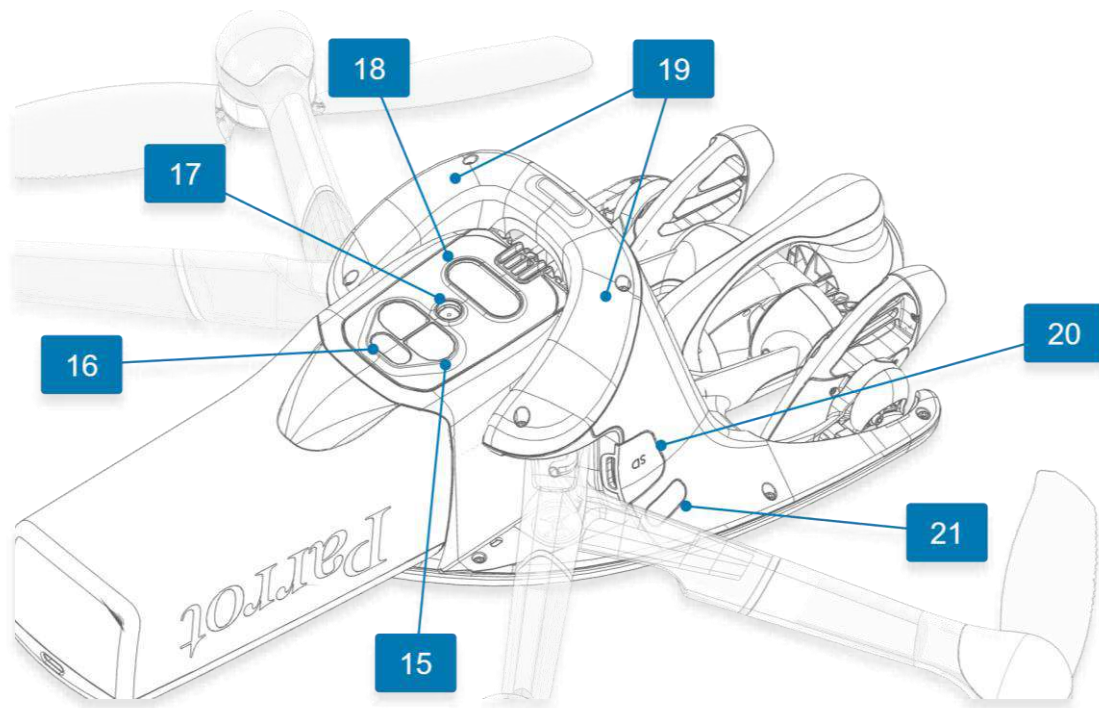

- | | |
|--|---------------------------|
| 15. Time of Flight (ToF) | 19. Secondary 4G antennas |
| 16. Bottom LED | 20. SD Card cover |
| 17. Vertical camera | 21. Left LED |
| 18. Low light & low altitude assistance lights | |

LEDs and assistance lights

LEDs ensure ANAFI Ai's visibility, and help visualize the drone's orientation in flight.

The right LED flashes for 0.4 seconds every 2-second cycle.

The left LED flashes for 0.4 seconds every 2-second cycle.

Both right and left LEDs are dimmed when the drone is landed.

The bottom LED is off when the drone is landed. It flashes in green for 0.4 seconds every 2-second cycle when the drone is flying.

LED luminosity increases with the drone's height over its take-off point, up to 5 meters.

Assistance white lights turn on in low light conditions, when ANAFI Ai is flying between 0.25 and 5.9 meters above ground.



Turn off ANAFI Ai

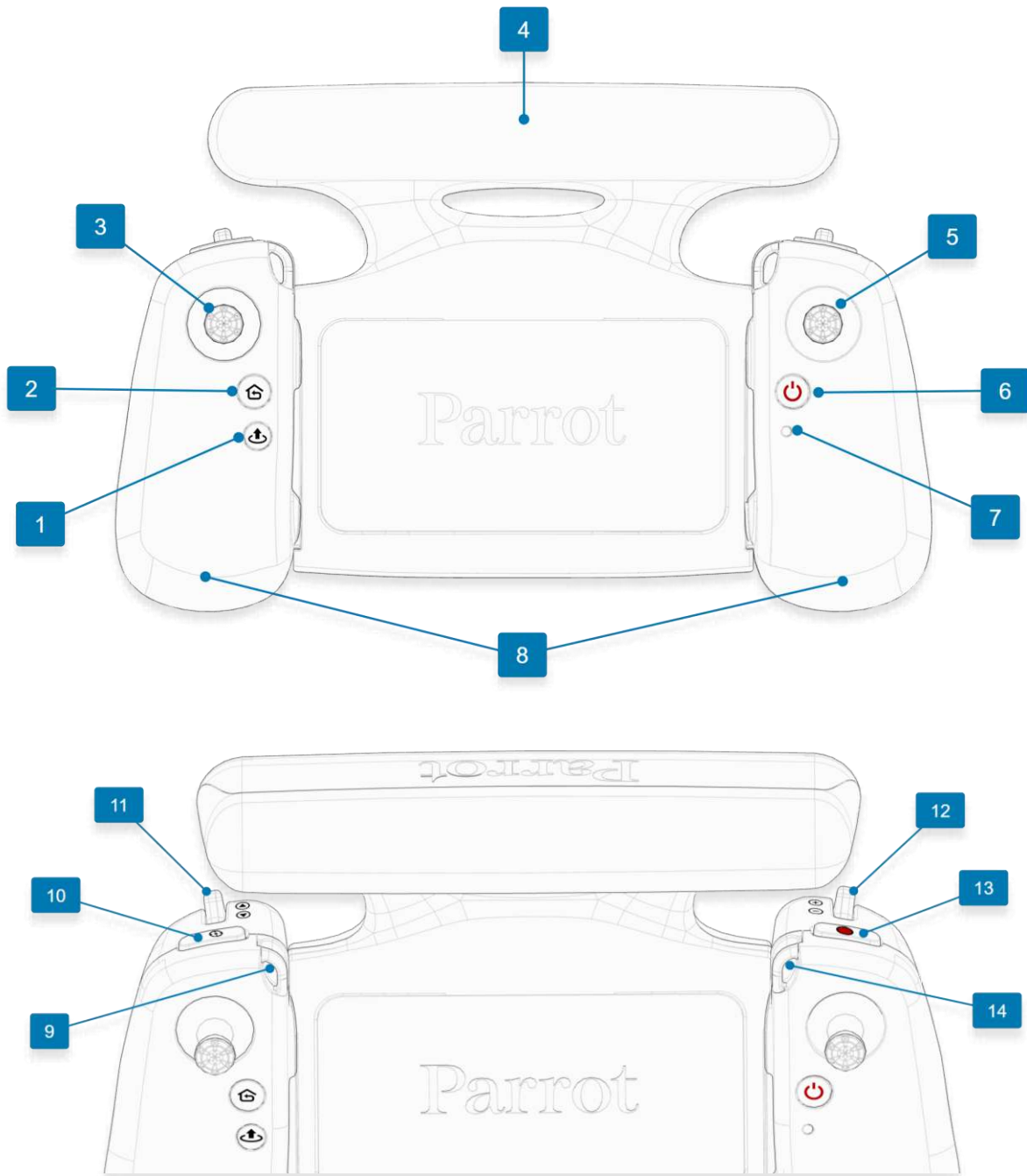

Press and hold the  **Power** button of ANAFI Ai for approximately 3 seconds (until all the battery's LEDs light off) to turn it off.

To ensure that the ANAFI Ai is completely switched-off, remove the battery from the body of the drone (Ensure that the drone is safely landed on the ground, without any running propeller).

Presentation of Skycontroller 4



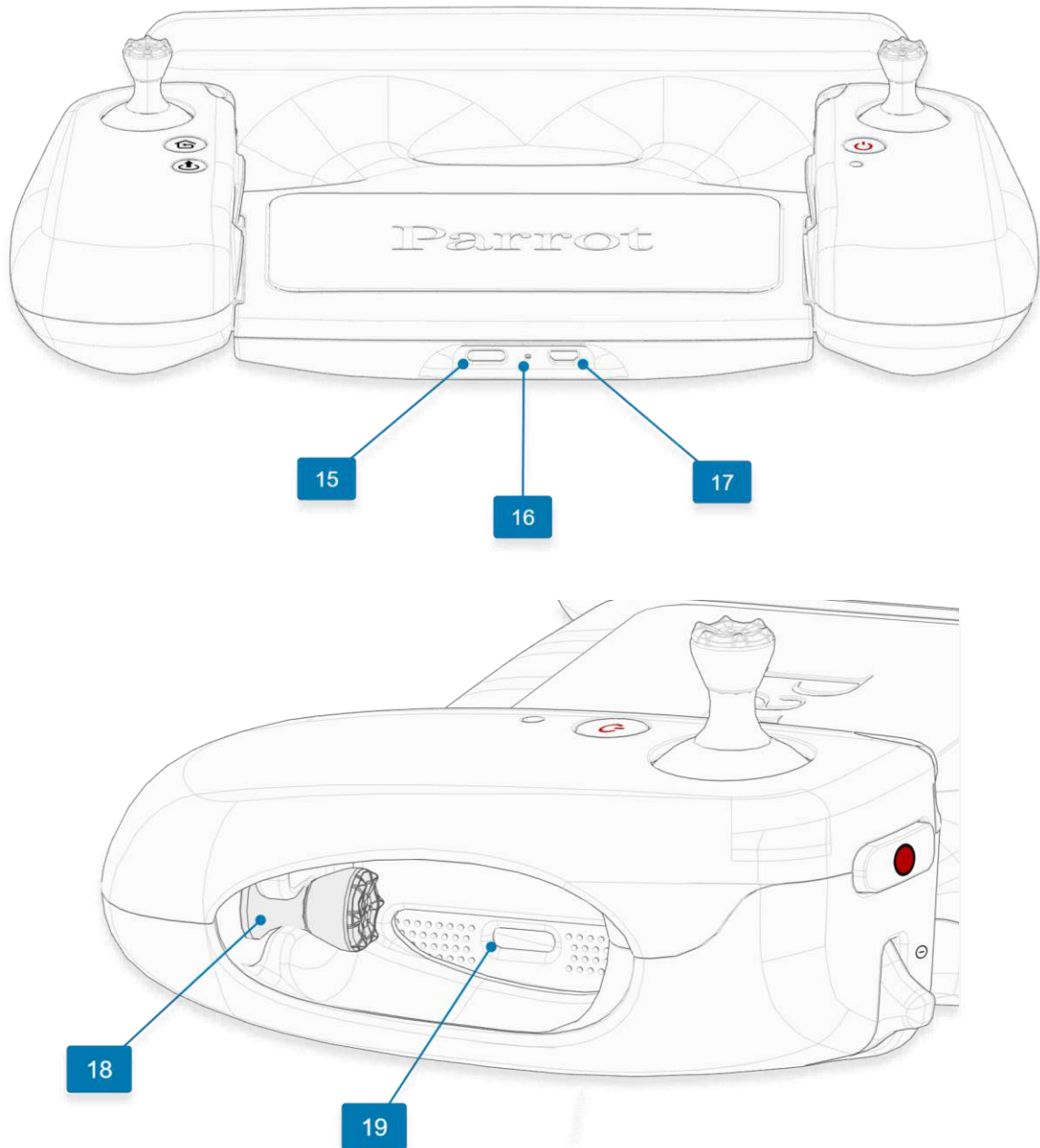

1.  **Take-off/Land** button
2.  **RTH** (Return to Home) button
3. Left detachable joystick
4. Wi-Fi antenna
5. Right detachable joystick
6.  **Power** button
7. Status LED indicator

8. Sliding handles
9. Left neck strap loop
10.  **Optics reset**
11. **Gimbal Tilt** trigger
12. **Zoom** trigger
13.  **Media recording**
14. Right neck strap loop



- 15. USB – C charging port
- 16. Charging LED
- 17. Micro - HDMI port

- 18. Left spare joystick storage (1 of 2)
- 19. USB – C device connection port





WARNING. If you press  **Take-Off/Land**,  **RTH**, and  **Media Recording** simultaneously, the EMERGENCY MODE on ANAFI Ai activates immediately. EMERGENCY MODE instantly cuts power to all motors on ANAFI Ai, which causes the drone to fall from the sky.

Refer to the “[Flying](#)” section for more information.



LED Status indicator color codes

When the Parrot Skycontroller 4 is powered on, its status LED indicator (number 7 on image) and its charging LED (number 16 on image) provide an instant visual indication:

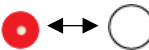
Status LED indicator colors and behavior



| | | |
|---|----------------------------------|--|
|  | Flashing green | Skycontroller 4 update in progress |
|  | Alternating light blue/dark blue | Connecting to ANAFI Ai |
|  | Flashing light blue | No drone configured or incorrect WPA key |
|  | Steady dark blue | Connected to ANAFI Ai |
|  | Alternating purple/dark blue | RTH in progress |
|  | Alternating red/any color | Low battery alert (ANAFI Ai, Skycontroller 4, or both) |

Charging LED colors and behavior

| | | |
|---|----------------|----------|
|  | Flashing green | Charging |
|  | LED off | Charged |

Pairing ANAFI Ai to a Skycontroller 4

Follow this procedure to pair a drone and a controller for the first time, and to restore the lost pairing between a drone and a controller.

1. Verify that a compatible microSD card is inserted into ANAFI Ai.
2. Press  **Power** on ANAFI Ai.
3. Press  **Power** on Parrot Skycontroller 4.
4. Connect the drone to one of the USB-C ports of the controller (side or bottom) with a USB-C to USB-C cable.
5. The LED of the Parrot Skycontroller 4 repeatedly flashes green to indicate it acknowledges ANAFI Ai, and to establish pairing protocols.
6. Wait for synchronization between Parrot Skycontroller 4 and ANAFI Ai. The controller shows a steady dark blue LED.
7. Verify that the left trigger of the Parrot Skycontroller 4 activates the drone's gimbal to ensure the synchronization is complete.
8. Disconnect the controller from the drone.

HDMI video sharing

Use a micro-HDMI to HDMI cable to connect the Skycontroller 4 to an external screen (or VR goggles). The screen displays ANAFI Ai's video stream.

NOTE: External screens only display the drone's video stream, and none of the additional information provided by FreeFlight 7. Operators can watch the drone's view on an external screen, while they navigate FreeFlight 7 menus (settings or dashboard) on the device associated to the Skycontroller 4.

Parrot recommends using a certified micro-HDMI to HDMI cable (not included in the box) to connect external pieces of equipment to the Skycontroller 4. Uncertified cables may impair the ecosystem's Wi-Fi performance.

GPS receiver compatibility

You can connect an external GPS receiver alongside the Skycontroller 4 to improve device location accuracy.

To use a GPS receiver:

1. Connect a USB hub to the USB-C port at the bottom of the Skycontroller 4.
2. Connect the GPS receiver to the USB hub.

The external receiver signal is now used instead of the iOS device for positioning in Follow-Me, Vehicle mission etc.

Supported GPS modules:

- Any USB GNSS receiver based on the u-blox 8 or u-blox 9 family of chipsets.

4G Connectivity

If 4G coverage is available, ANAFI Ai has no range limit, other than that of its battery. Pilots can conduct BVLOS (beyond visual line of sight) flights.

IMPORTANT: Research local regulations before you use 4G connectivity. Some countries may restrict or prohibit drone connections to local 4G networks, even in areas where drone operations are permitted. If there are 4G connectivity restrictions, turn off **Cellular access** in the FreeFlight 7 application and use the Wi-Fi connection only. Refer to the “[Settings / Advanced / Connection](#)” section for more information.

4G connectivity offers improved communications between the drone and controller, particularly in environments that experience high levels of interference, such as urban areas.

By default, when a compatible nano SIM card is inserted in ANAFI Ai and activated, the Skycontroller 4 optimizes its connection with the drone, choosing between Wi-Fi and 4G network, automatically and in real time.

NOTE: In FreeFlight 7, go to **Settings > Advanced > Connection** to choose between Wi-Fi priority or 4G priority. Refer to the “[Settings / Advanced / Connection](#)” section for more information.

Temporarily switching this setting to **4G priority** before a flight enables you to assess the strength of your 4G connection. Select **Wi-Fi priority** then revert to **Auto** to take off using Wi-Fi.

IMPORTANT: 4G connection and in flight 4G data sharing may incur charges, according to the 4G data plans associated to your drone and device SIM cards.

Installing and retrieving the nano SIM card

The nano SIM card slot is located on the right-hand side of the drone, under the **4G** cover. To install the nano SIM card, lift the cover open and insert the nano SIM card straight into the slot, shortest side first with the connectors turned to the back of the drone. For more information, refer to the diagram on the inside of the 4G cover. To retrieve the nano SIM, press the card and extract it.

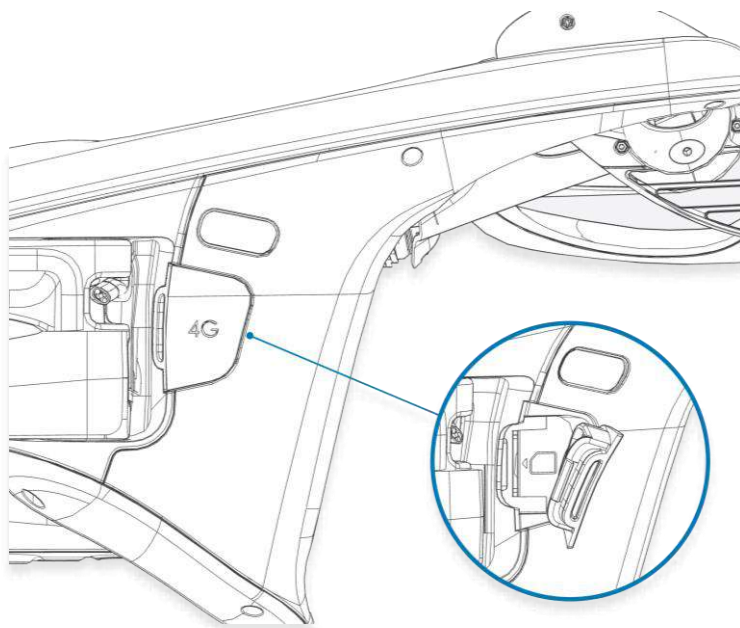

Activating the nano SIM card

NOTE: Parrot recommends that you create a Parrot.Cloud account, however it is not mandatory to activate ANAFI Ai’s 4G functions.

To activate the nano SIM card, power on the full ANAFI Ai ecosystem (drone, Skycontroller 4, device). Access the ANAFI Ai page of the homescreen. The **Cellular access** tile status is **SIM locked**.

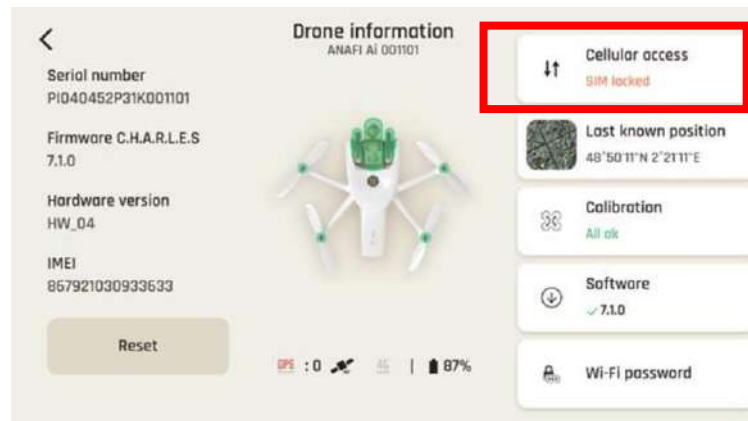

Cellular access SIM locked

Tap the **Cellular access** tile to open the **Cellular access** interface.



Cellular access interface

If applicable, tap **Enter PIN** to access the **SIM card PIN** interface.

Enter your pin and tap **Ok** to confirm. The interface closes after approximately 3 seconds, and the 4G protocols are activated. The **Cellular access** tile status now shows **Connected 4G**.

Tap the **Cellular access** tile again to check the corresponding interface, displayed below.

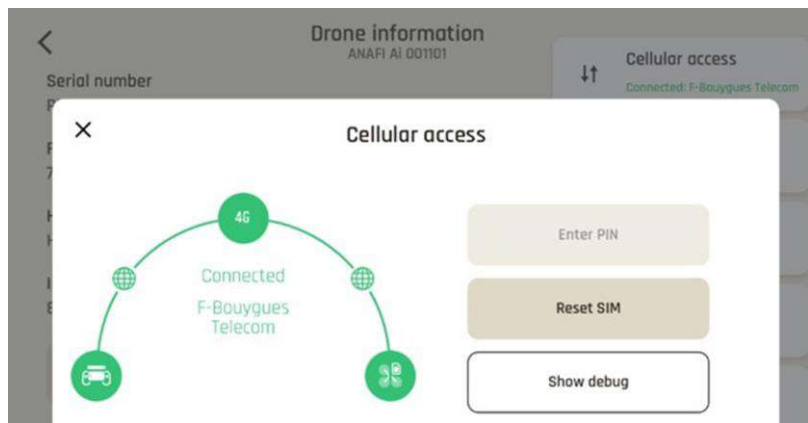

Cellular access interface

NOTE: If you select **Reset SIM** from this interface and then confirm, the drone reboots with a **SIM locked** status.

Data sharing and User accounts

Parrot highly values your privacy and the security of your data. The FIPS140-2 compliant & CC EAL5+ certified Secure Elements and strong authentication for 4G feature of the ANAFI Ai ecosystem provide absolute protection for your workflow.

This section describes the three data sharing options available for ANAFI Ai owners and operators, in connection with the Parrot.Cloud account. PIX4D accounts are also covered in this section.

Anonymous sharing (default option)

From the FreeFlight 7 homescreen, tap **Log in** to access data sharing and account options.

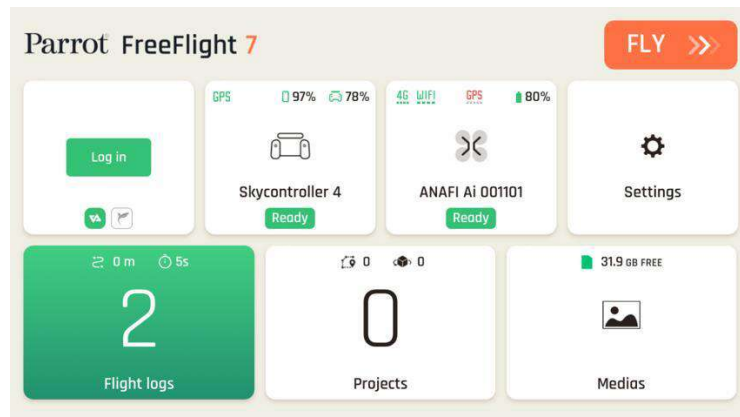

FreeFlight 7 homescreen

By default, on first launch and as the ecosystem is free from all links to Parrot or partners accounts, FreeFlight 7 forwards anonymous software data to our servers, which helps Parrot improve its products.

NOTE: The FreeFlight 7 homescreen may display existing Flight Logs on first start up. These flight logs are:

- The initial start-up (considered as 1 flight log)
- Conformity/quality testing during production (considered as 1 flight log)

Your flight data is stored locally, between your FreeFlight 7 device and your drone, both protected by the Secure Elements and 4G strong authentication (if you have activated a nano SIM).

Tap **Data sharing**. The **Manage flight data sharing** screen opens:

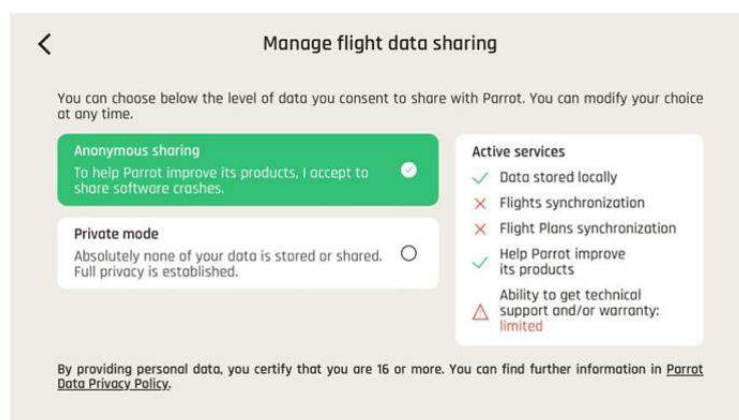

Manage Flight data sharing interface

Private mode (zero data)

From the **Manage flight data sharing page**, tap **Private mode**. FreeFlight 7 warns you that confirming this choice deletes all flight data from your device.

Tap **Continue**. No additional data will be recorded on your device until you revert to **Anonymous sharing**. **CAUTION:** If you activate **Private mode**, you limit your ability to receive technical support, warranty, or

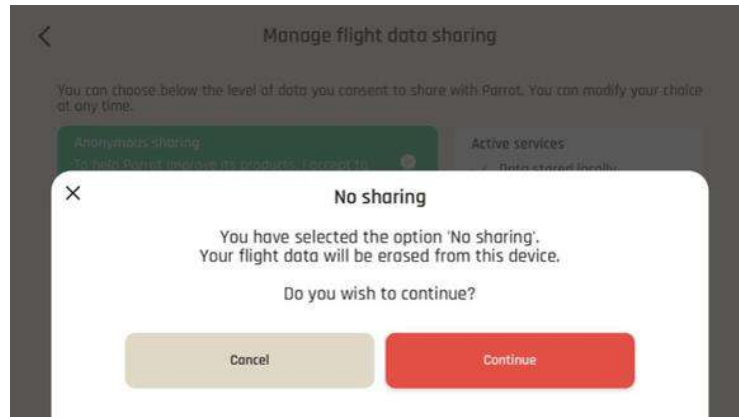

No sharing warning screen

both from Parrot Support. Although the ecosystem produces data to enable a safe flight, none of the data is saved after you power off the ecosystem.

Parrot.Cloud account & Full sharing

If you log into a Parrot.Cloud account, you can save your flight data and Flight Plans on the Cloud.

Creating a Parrot.Cloud account is optional, but this option also enables you to maximize your access to technical support, warranty, or both.

Create an account or **Log in** to your existing Parrot.Cloud account from the next screenshot interface and follow in-app instructions. Creating a Parrot.Coud may require a confirmation from your email account before full activation.



Create an account/Log in interface

After you log into your Parrot.Cloud account, by default, the **Full sharing** option is activated.

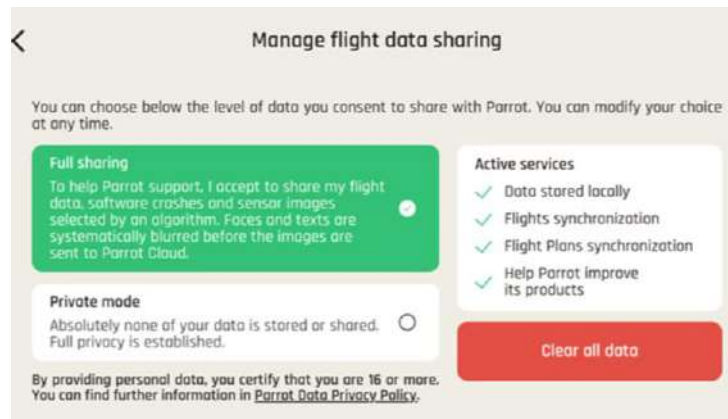

Manage flight data sharing - Full sharing

CAUTION: If you tap **Clear all data**, you delete all your data from your device (and from the Cloud, if you decide so). This is useful for multi-operator drones.

PIX4D account

Existing PIX4D users can link their account to their drone and start programming photogrammetry missions directly from FreeFlight 7 and 4G upload to PIX4D.

If you are a new user and you create a PIX4D account, you can use 3 offered photogrammetry models.

Tap the **PIX4D** tile to log in to your PIX4D account or create a PIX4D account. Follow the in-app instructions to proceed to the PIX4D **Connect** page.

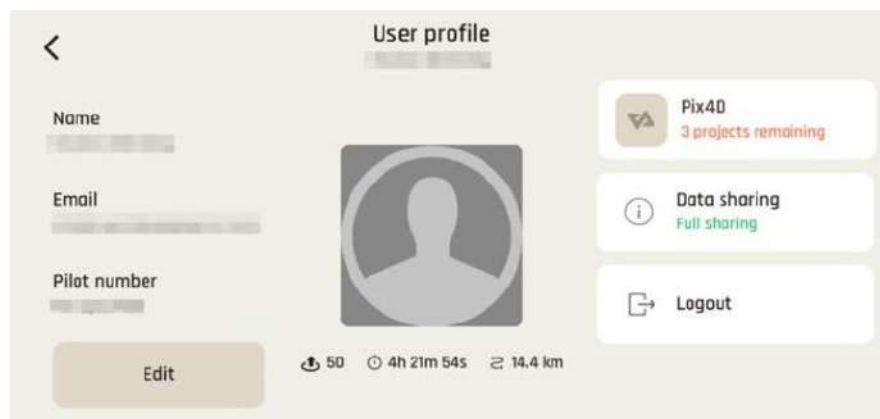

User profile interface, PIX4D tile





Follow the in-app instructions to log in or create an account. You may receive a verification link via email. Click the link to activate your PIX4D account.

Refer to the "[Missions: Photogrammetry](#)" section for more information.

Obstacle avoidance

The drone's obstacle avoidance (OA) system relies on stereo cameras, located on each side of the main camera. Ensure that the lenses of the stereo cameras are always perfectly clean. Use specialized photo lens cleaning liquid to clean the optics.

Go to **Settings > Quick** and tap the **Obstacle avoidance** tile to activate the OA system. The OA system status is displayed on the HUD, through a shield icon in the top bar:

| | |
|--|--------------------------------------|
|  | OA activated and operating optimally |
|  | OA activated, degraded operation |
|  | OA activated, but inoperative |
|  | OA deactivated |

Parrot strongly recommends deactivating the OA whenever the icon is NOT green.

If you see a Stereo camera failure notification with a red OA shield, deactivate the OA immediately, land your drone as soon as possible and reboot all systems (drone, controller, app) before attempting another OA activation. You may have to recalibrate the Obstacle avoidance system before you can activate OA again. Refer to the "[Calibrations / Obstacle avoidance calibration](#)" section for more information.

Possible causes of disabled obstacle avoidance and the associated warnings on the HUD include:

- **Environment too dark**
- **Stereo sensors calibration required**
- **Stereo camera failure**

Obstacle avoidance and manual piloting

The OA is designed to assist the pilot. It is not designed to replace the pilot's control over the drone.

WARNING: Do not lose sight of the drone and always remain focused on its flight.

You must:

- Rely on your own judgement to control the drone and manually avoid obstacles.
- Be wary of obstacles, in particular people and animals which may find themselves in the trajectory of the drone.
- Keep the speed of your drone under 8 m/s.
- Set an RTH altitude before each flight.

When you fly the drone in a direction where the OA cannot detect obstacles (directly sideways or sideways and toward the back), a notification appears on your screen: **Obstacle avoidance – Drone blind in this direction**.



Obstacle avoidance blind spot

Face the drone in the direction of travel to avoid getting this notification.

Obstacle avoidance and automated flights

During automated flights, the drone manages its trajectory to keep the OA fully functional.

However, you must carefully plan and monitor your automated flights in the following conditions, as the OA might not work optimally.

- Dynamic (moving) environments.
- In front of surfaces or objects that are:
 - monochrome (plain white or black, on any other color without distinct texture or motive);
 - reflective;
 - water based or transparent;
 - mobile;
 - very dark or very bright.
- In areas where the lighting conditions change drastically or very rapidly.
- In rainy conditions.

Calibrations

This section presents the calibration procedures available on the ANAFI Ai and the Skycontroller 4.

Skycontroller 4 calibration

1 Skycontroller calibration option is available. FreeFlight 7 may require you to calibrate the magnetometer of your Skycontroller 4 if it has been exposed to a strong magnetic field, or if your flying conditions change radically (for example, if you change from one continent to another).

You must perform a Skycontroller calibration when the Skycontroller 4 page from the FreeFlight 7 homescreen displays a **Calibration required** alert on the Skycontroller 4  **Calibration** tile:

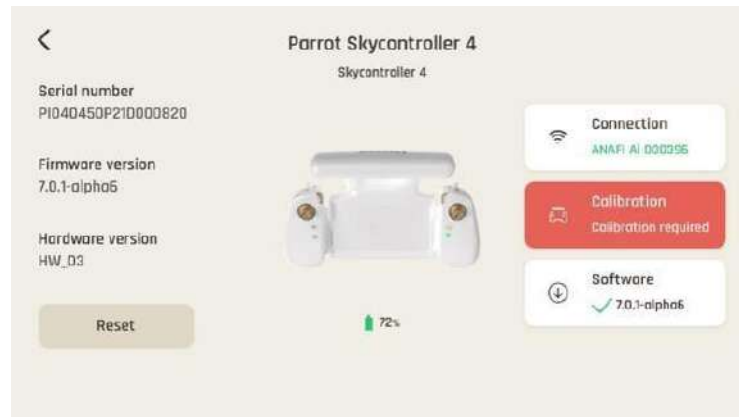

*Skycontroller 4 page on FreeFlight 7, **Calibration required***

Tap the  **Calibration** tile to open the **Magnetometer calibration** screen.

Tap **Calibrate**.

Follow the on-screen instructions to complete the calibration. Reproduce the movements displayed on the **Magnetometer calibration** screen:

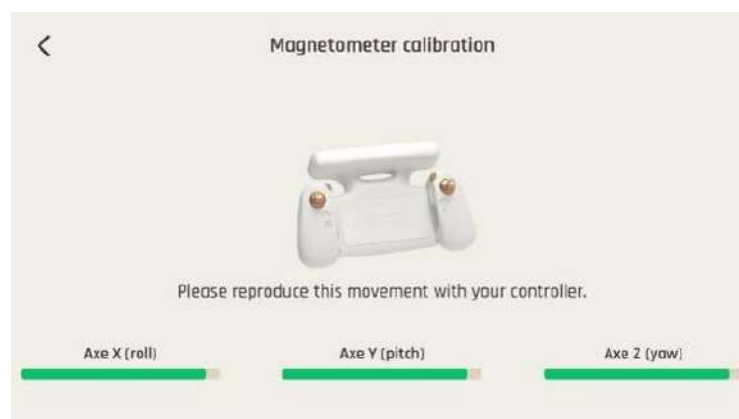

Skycontroller 4 calibration in progress

When you tap the **Calibration** tile of the ANAFI Ai on the FreeFlight 7 homescreen, the **Calibration** menu opens and displays 4 drone calibration options:

- **Gimbal**
- **Correct horizon**
- **Magnetometer**
- **Obstacle Detection**

Gimbal calibration

Position ANAFI Ai on a perfectly flat and level surface. In the **Calibration** menu, tap the **Gimbal** tile to perform a gimbal calibration. The gimbal calibration is more precise than the quick calibration which occurs when ANAFI Ai is powered on. Both the main camera and the stereo camera gimbals calibrate successively.

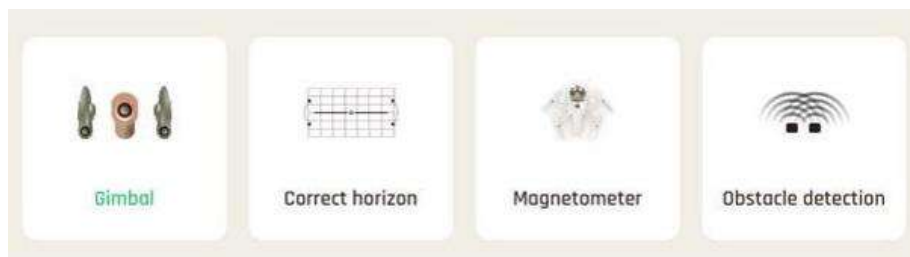

ANAFI Ai Calibration options

The Gimbal calibration screen opens and informs you that the **LOVE camera calibration** is in progress.

NOTE: Gimbal calibration is not mandatory to take off, but it is recommended. FreeFlight 7 can prompt you to perform this calibration when required.

Correct horizon calibration (exceptional procedure)

If all your videos and photos have a tilted horizon, and if this tilt is always on the same side, you must correct the horizon.

IMPORTANT: Do not perform the horizon calibration unless it appears necessary, for example, after a crash. This is different to the magnetometer calibration of ANAFI Ai or the Skycontroller 4, which you must perform periodically,

Position ANAFI Ai on a perfectly flat and level surface, exactly perpendicular to any pattern containing straight lines you can use as horizon references.

TIP: A large water bottle half full of water provides a useful horizon line almost anywhere.

When ANAFI Ai is correctly positioned, perpendicular to a horizon, press **Power**, along with the Parrot Skycontroller 4 and your device.

In the **Calibration** menu, tap the **Correct horizon** tile to perform a horizon calibration.

TIP: This feature is also accessible from the ANAFI Ai box of the HUD.

Tap + **plus** or – **minus** until the artificial horizon of ANAFI Ai matches the horizon reference facing the drone.

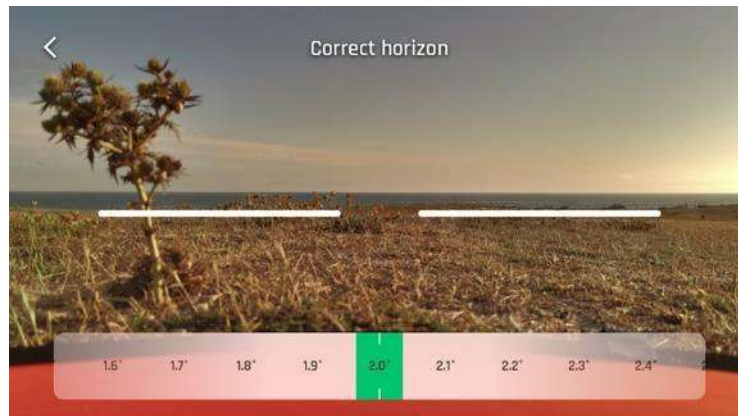

Correct horizon procedure

When you complete the procedure to straighten the tilt of the camera, tap < **back** on the top left of the screen to confirm your setting and exit horizon calibration.

Magnetometer calibration

In the **Calibration** menu, tap the **Magnetometer** tile to perform a magnetometer calibration. You must unfold the arms on the drone before you begin the calibration. Tap **Start** on the **Magnetometer calibration** screen to begin the calibration.

Follow the on-screen instructions to perform a calibration for:

- **AXE Z (YAW)**
- **AXE Y (PITCH)**
- **AXE X (ROLL)**

Reproduce the movements in the animations displayed on the screen for each axe. The current axe being calibrated is highlighted in green. When you complete a calibration for one axe, a checkmark in a green circle appears to the left of the axe title.

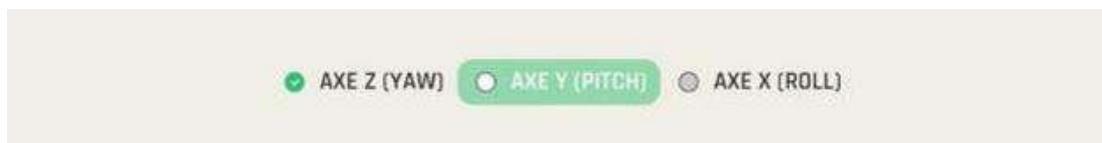

AXE Z calibrated, AXE Y calibration in progress, AXE X uncalibrated

Obstacle avoidance calibration

To calibrate the obstacle avoidance system, set up your full ecosystem for a flight. **Obstacle avoidance calibration** requires a short upward flight in a straight line, and a full 360° rotation of the drone.

IMPORTANT: You must always perform an **Obstacle avoidance calibration** out in the open, ideally in a zone fully authorized to drone flights.

NOTE: Obstacle avoidance is deactivated during this procedure.

In the **Calibration** menu, tap the **Obstacle detection** tile to open the **Obstacle avoidance calibration** interface.

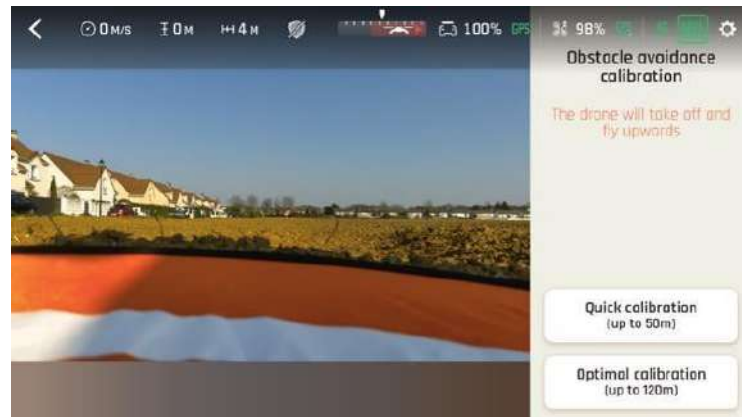

Obstacle avoidance calibration interface

2 calibration options are available:

- **Quick calibration (up to 50m)** – Use this option in zones where you are not permitted to fly drones higher than 50 meters. This calibration is slightly downgraded, and it should only be used in the flattest environments.
- **Optimal calibration (up to 120m)** – Use this option whenever possible. This calibration provides the highest quality calibration.

Tap either the **Quick calibration**, or **Optimal calibration** tile to select it. ANAFI Ai takes off, reaches the selected height, performs a full 360° rotation and descends.

FreeFlight 7 prompts you to land the drone to complete the calibration.

When the drone lands, the obstacle avoidance calibration sequence is complete. The  **Take-off/Land** icon is replaced by a green check mark.

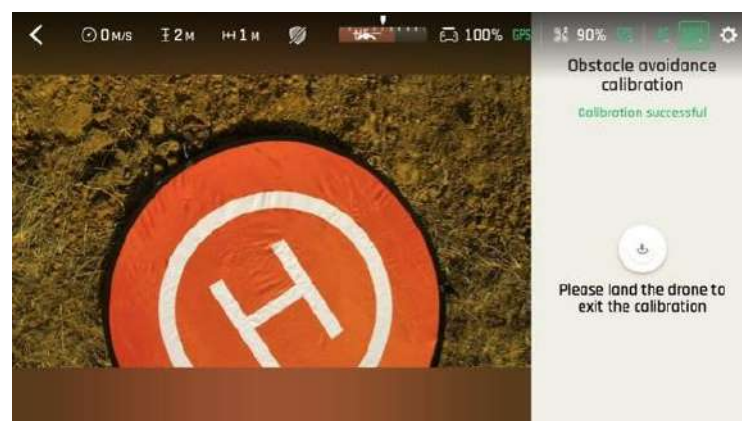

Obstacle avoidance calibration successful

Pre-flight checklist

Transport & handling

- Always transport ANAFI Ai in its hard case, safely positioned, with the gimbal's protection cover on.
- Always transport the Parrot Skycontroller 4 safely in the relevant location in the hard case.
- Protect the battery from temperature extremes, both low and high. Try to keep the battery as close as possible to ambient temperatures.
- Always handle the ANAFI Ai with care. Do not apply pressure to the drone and generally avoid touching the sensitive camera and gimbal.
- Always keep the hard case with the drone and battery in dry places.

Equipment

- Ensure that you download the latest version of FreeFlight 7, and that both your Skycontroller 4 and your ANAFI Ai are up to date with the latest versions of firmware.

IMPORTANT: Updates are mandatory and must be performed systematically prior to any flight to ensure maximum performance and safety.

- Ensure that you have the correct USB-C to Lightning cable to connect your Skycontroller 4 and your device.
- Ensure that you insert a microSD card with enough free memory space into the drone.
- Ensure that you unfold all four foldable arms of the drone.
- Ensure that the propellers are clean, intact, and unobstructed.
- Ensure that both the ANAFI Ai's and Skycontroller 4's batteries are fully charged.
- Ensure that you always use genuine Parrot smart batteries. Non-genuine batteries are forbidden, and their use will void the warranty and impact safety requirements.
- Ensure that the drone's battery is securely installed on the drone's body.
- Ensure that the drone's gimbal protective cover is removed.
- Ensure that the drone's lenses are clean. If the lenses require cleaning, clean them before you press  **Power** on the drone. Hold the gimbal between two fingers so that you do not apply pressure to the mechanism. Gently wipe the lens with a microfiber cloth.

Regulations

- Ensure that drone use is permitted where you intend to fly.
- Check for potential restrictions regarding the use of Wi-Fi frequencies in the area where you intend to fly.



Flight conditions

- Ensure that the flying zone is safe and clear.
- Do not fly ANAFI Ai at night.
- Do not fly ANAFI Ai over urban areas or over restricted airspaces such as airports, train stations, power plants, national reserves, etc.
- Check the weather. Do not fly ANAFI Ai in fog, snow, hail, salt spray, thunderstorms, sandstorms, bird flocks, or in wind exceeding 15 m/s (33 mph).
- Parrot recommends you do not fly ANAFI Ai low over water and other reflective surfaces, such as mirrors, glass, etc).

Getting started

1. Charge the battery using one of the enclosed USB-C to USB-C cables and the enclosed charger. Refer to the "[Smart LiPo Battery / Battery charging](#)" section for more information.

Parrot recommends you always fully charge all batteries before flying before flying ANAFI Ai. Fly ANAFI Ai with the Skycontroller 4, and a device, for the best flight experience.

2. Ensure that your flying zone is safe and clear.
3. Unfold the arms.
4. To start the drone, place it on a flat horizontal surface and press  **Power** for approximately 3 seconds until the drone's fan starts turning.
5. Press the Skycontroller 4's  **Power** button for 3 seconds, wait for the steady dark blue light, then connect your device to the controller using a USB-C to Lightning cable.
6. FreeFlight 7 runs automatically on your device and connects to ANAFI Ai and to Parrot Skycontroller 4.
7. Systematically check for FreeFlight 7, Skycontroller 4, and ANAFI Ai software updates to ensure maximum performance and safety.



IMPORTANT: Parrot strongly recommends that you regularly refer to the [Release Notes ANAFI Ai](#) available on the Parrot website, to ensure that you have the latest versions of the drone and controller firmware, and FreeFlight 7 App.

8. Calibrate your ANAFI Ai, your Skycontroller 4, or both, if required. Follow the instructions on your device's screen to complete the calibration.
9. Ensure that your flying zone is still safe and clear, and that no person or animal has approached or is approaching ANAFI Ai.
10. Stay at least 2 m (6 ft) from the drone and press  **Take-off/Land** to start the flight operation.

CAUTION: As a safeguard measure, ANAFI Ai is programmed to cut its motors instantly in case of impact on one of its propeller blades. Always control your drone carefully.

Taking off

Ground take-off

1. Position ANAFI Ai on a flat, even, and clear surface.
2. Press  **Power** on ANAFI Ai
3. Move at least 2 m (6 ft) away from ANAFI Ai
4. Check that the surroundings of the drone are absolutely clear.
5. Press  **Take-off/Land** on your Parrot Skycontroller 4.

ANAFI Ai takes off and stabilizes at 1 m (3 ft) from the ground, waiting for commands from the pilot.

Hand launch

A hand launch procedure is more dangerous than a ground take-off. Be especially careful with the hand launch feature. It requires complete focus. Do not become distracted and stay aware of your surroundings.

WARNING: DANGEROUS MANEUVER. RISK OF BODILY INJURY AND DAMAGE TO THE DRONE IN CASE INSTRUCTIONS ARE NOT FOLLOWED. LACERATION HAZARD. Do not touch the propeller blades during flight. Propeller blades can cause deep cuts if your fingers, or other body parts, come into contact with them. Keep the drone as far away from your face as possible. PARROT STRONGLY RECOMMENDS THAT YOU DO NOT PERFORM A HAND LAUNCH PROCEDURE INDOORS, DUE TO LOW STABILITY, AND INCREASED RISK.

Parrot recommends that you work as a team of two people: one person to perform the take-off procedure, while the other person focuses on flying the drone.



Pay attention to the wind direction and speed. Do not face the wind. Keep yourself at a safe distance from the drone considering the possibility of drifting with the wind.

1. Press  **Power** to power on ANAFI Ai.
2. Position the drone on your flat, open hand.

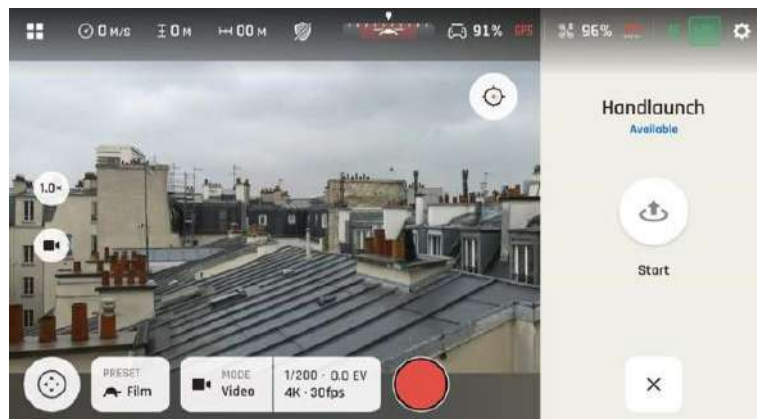
The **Handlaunch Available** interface appears on the right-hand side of your device's screen.



Handlaunch interface

3. Press  **take-off/Land** on your Skycontroller 4, or tap  **take-off/Land** on your device's screen.

The drone's propellers start to rotate slowly.

4. Wait until the propellers' rotation speed stabilizes, then briefly and rapidly lift ANAFI Ai up and forward with your open hand.

ANAFI Ai becomes airborne. It stabilizes and waits for commands from the pilot.

Only perform a hand launch procedure when there is no other launch alternative.

CAUTION: In environments with sand, you can use hand launch, instead of ground take-off to prevent sand from penetrating the motors.

Flying

Left joystick
(Default mode)

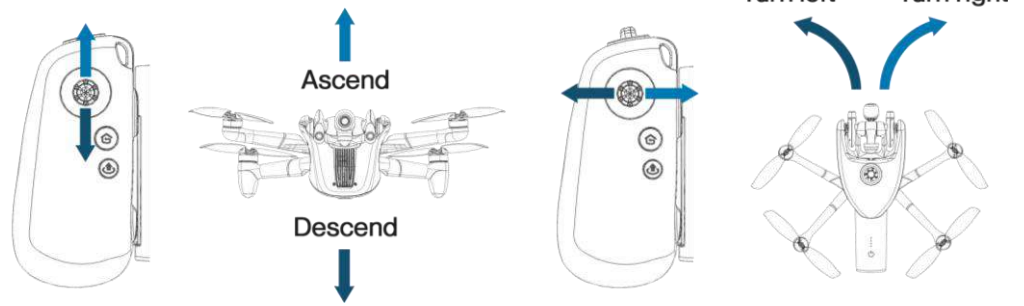

Right joystick
(Default mode)

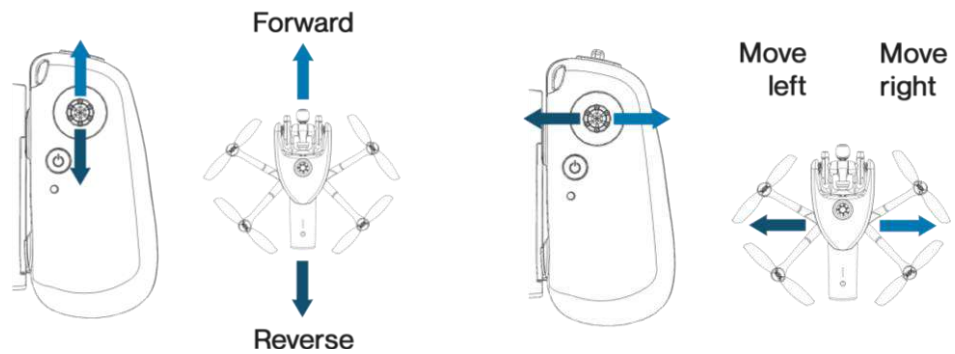

NOTE: You can modify ANAFI Ai's controls through the **SETTINGS** menu of FreeFlight 7. Refer to the [“Settings / Controls”](#) section for more information.

WARNING. ANAFI Ai features an emergency mode. Activating the EMERGENCY MODE button sequence in flight will immediately result in a full motor cut out and instantly forces the drone to crash to the ground.

To activate EMERGENCY MODE, press the following buttons on Skycontroller 4 simultaneously:

-  RTH
-  Take-off/Land
-  Media recording

Notably, the EMERGENCY MODE meets the regulatory requirement for Specific category flights in French national standard scenarios S1 & S3. The use of this mode is at the user's responsibility.

Returning home: Smart RTH

To use the return home feature, ANAFI Ai must set a **home point**. This is achieved with the first GPS fix of the drone.

TIP: Ensure that the drone GPS icon is green before you take-off:



Both GPS icons are green - RTH position set

If no GPS fix is possible from the ground, you must fly ANAFI Ai upward in a straight line over the take-off point until the drone synchronizes with enough satellites to turn the GPS icon green. This ensures the **home point** is directly over the current take-off point.

To return ANAFI Ai to the **home point**, press  **RTH** on your Parrot Skycontroller 4.

By default, ANAFI Ai rises to 50 meters above its take-off point and flies back over its **home point**.

TIP: In FreeFlight 7, you can set a custom altitude between 20 and 100 meters for the RTH height. Refer to the [“Settings / Advanced / RTH”](#) section for more information.

Low battery Smart RTH

ANAFI Ai features a Smart RTH capability. When battery power is low, FreeFlight 7 alerts you that it will enter Smart RTH mode. If you feel confident you can bring ANAFI Ai back to its take-off point, or if you wish to land it at a different location, you can cancel the Smart RTH directly from the alert pop-up.

IMPORTANT: Low battery is determined by a number of factors, including altitude, distance from the **home point**, and wind speed. The drone computes in real time the battery power it requires to return home, or to the pilot. Refer to the [“Settings / Advanced / RTH”](#) section for more information. If you cancel the RTH on low battery, the drone makes an emergency landing at its current position if it does not have enough battery power to continue flying.

Ecosystem link loss Smart RTH

ANAFI Ai switches seamlessly between Wi-Fi and 4G to avoid a complete connection loss between the elements of the ecosystem. If the Wi-Fi signal is weak, or there is significant interference (for example,



due to powerlines), a warning appears on your device’s screen:  **Weak Wi-Fi signal. Strong interferences**. When connected to Wi-fi, the Wi-Fi icon on the top right of the screen is inside a box. The icon appears red when the signal is weak.

When the switch to 4G is complete, the 4G icon is inside a box. The icon appears green when the signal is sufficient.

In the unlikely event of a complete loss of connection between the controller and the drone that lasts for more than 12 seconds, ANAFI Ai automatically enters Smart RTH mode.

This behavior (drone rises to RTH height and starts route toward home) ensures a quick recovery of pilot control over the drone, in most cases.



Pilot Smart RTH

When you select **Pilot** advanced RTH mode, ANAFI Ai returns to the GPS position of the device used to control the drone at the exact moment an RTH procedure is activated, whether the drone is linked to a Parrot Skycontroller 4 or not. If the drone loses the GPS fix, it returns to the last known coordinates of the device.

Parrot recommends that ANAFI Ai pilots remain in the same location, after activating an RTH procedure, when in **Pilot** advanced RTH mode.

NOTE: You can choose the RTH end altitude to be:

- Ground (0 m)
- A hovering altitude (1 m – 10 m)

When the horizontal distance between the drone and the home position is less than 5m

- If the RTH is caused by an ice alert, or a battery communication loss, the drone descends to the altitude set for the RTH end, or lands depending on the RTH ending selected behavior.

For other RTH reasons,

- If the precise home feature is available, the drone:
 1. rises to 10 m above ground level,
 2. moves horizontally towards the home location,
 3. descends with the aid of precise home.

Otherwise, the drone descends directly to the altitude set for the RTH end, or lands depending on the RTH ending selected behavior.

When the horizontal distance between the drone and the home position is between 5 m and 100 m:

If the precise home feature is available, the drone performs an RTH

Landing.

Fly ANAFI Ai directly over a flat, even, clear surface. Press  **Home**, ANAFI Ai Lands.



Landing in progress

Hand landing

A hand landing procedure is more dangerous than a ground landing. Be especially careful with the hand land feature. It requires complete focus. Do not become distracted and stay aware of your surroundings.

CAUTION: DANGEROUS MANEUVER. RISK OF BODILY INJURY AND DAMAGE TO THE DRONE IN CASE INSTRUCTIONS ARE NOT FOLLOWED. LACERATION HAZARD. Do not touch the propeller blades during flight. Propeller blades can cause deep cuts if your fingers, or other body parts, come into contact with them. Keep the drone as far away from your face as possible. Only attempt a hand landing on a stable surface, with no obstacles in the immediate vicinity.

WARNING: PARROT STRONGLY RECOMMENDS THAT YOU DO NOT PERFORM A HAND LANDING PROCEDURE INDOORS, DUE TO LOW STABILITY, AND INCREASED RISK.

Do not attempt a hand landing in wind strong enough to make the drone fight to hold its hovering position.

Drone GPS synchronization is mandatory for a successful hand landing.

Let the drone do the work. Do not forcefully grab the drone while it is hovering.

Parrot recommends that you work as a team of two people: one person to perform the hand landing procedure, while the other person focuses on flying the drone. This eases the pressure of having to multi-task.

Pay attention to the wind direction and speed. Do not face the wind. Keep yourself at a safe distance from the drone considering the possibility of drifting with the wind.

Only perform a hand landing procedure when there is no other landing alternative.

CAUTION: In environments with sand, you can use hand landing, instead of ground landing to prevent sand from penetrating the motors.

ANAFI Ai recognizes your hand when it hovers more than 100 cm (3 ft) above your open hand, with your arm extended.

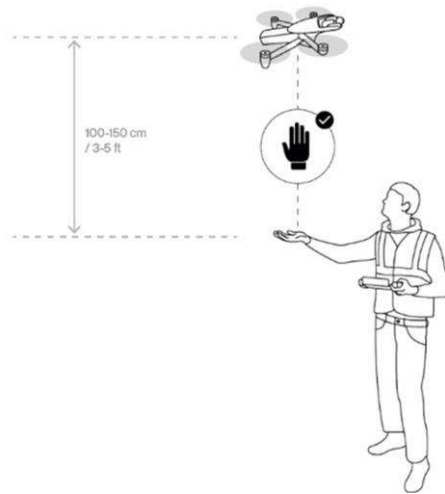

Hand landing diagram

Press  **Home** on your Skycontroller 4:

1. If necessary, ANAFI Ai rotates to align perfectly with your hand.
2. ANAFI Ai slowly and safely lands on your hand.

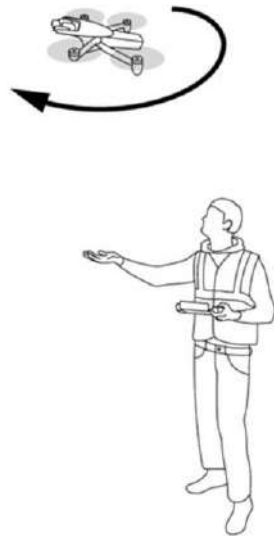

ANAFI Ai rotates to align with the pilots hand

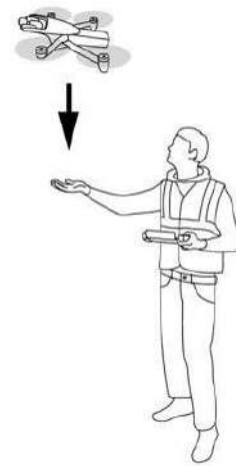

ANAFI Ai descends towards the pilot's hand

Note: During a landing procedure, if the ANAFI Ai is still flying at more than 100 cm (3 ft) from your hand, you can extend your arm under the drone, with your hand open. ANAFI Ai recognizes your hand and proceeds with the hand landing described above.

Only perform a hand landing procedure when there is no other landing alternative.

CAUTION: In environments with sand, you can use hand landing, instead of ground landing to prevent sand from penetrating the motors.

Smart LiPo Battery

The smart LiPo battery comes preinstalled on ANAFI Ai. You can charge the smart battery when installed on ANAFI Ai, or when removed from ANAFI Ai. If you remove the battery, you must reinstall it in the same orientation. Always use genuine Parrot smart batteries. Non-genuine batteries are forbidden, and their use will void the warranty and impact safety requirements.

IMPORTANT: The LEDs and  **Power** button face up in the correct orientation.

NOTE: LiPo batteries gradually lose capacity after 300 charge/discharge cycles.

Battery removal

To remove the smart battery from the drone, unfold the drone's arms, press the push-button located under the battery and disengage it from the drone by gently sliding it toward the back of the drone.

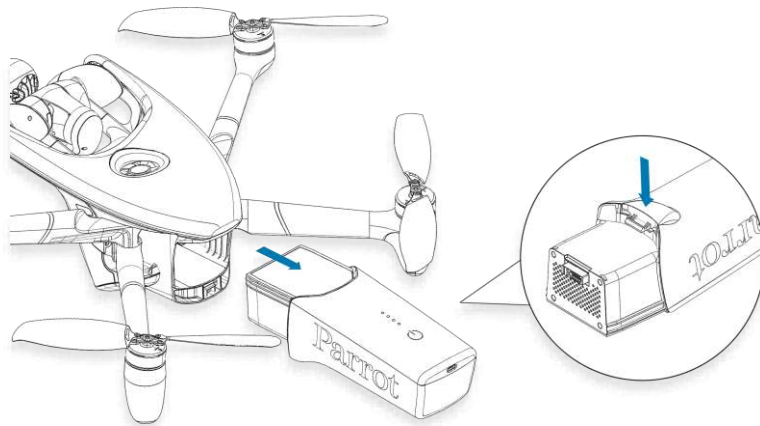

Battery installation

To install the smart battery on the drone, unfold the drone's arms, slide the battery firmly into the drone until you hear a click. Ensure that the battery is tightly secured into the drone.

Battery charging

To charge the smart LiPo battery, use one of the enclosed USB-C to USB-C cables to connect the battery to its enclosed charger. Alternatively, you can charge the battery from:

- a desktop or laptop computer's USB port.
- a power bank's USB-A port.

Full charging time depends on charger specifications and ambient temperature. At 20°C, you can expect your battery to be fully charged in 2 hours.

CAUTION: Other generic USB chargers may be used provided that they are certified according to the country of use, and have the applicable rating/specification. Performance and warranty are only guaranteed when using the genuine charger included in the Parrot drone system.

When ANAFI Ai's smart LiPo battery is plugged into a power source and charging, its 4 LEDs indicate the charge level:

| LED 1 | LED 2 | LED 3 | LED 4 | Charge Level |
|-------|-------|-------|-------|-------------------|
| | | | | 0 - 25% charged |
| | | | | 25 - 50% charged |
| | | | | 50 - 75% charged |
| | | | | 75 - 100% charged |
| | | | | Fully charged |

When the battery is not installed on ANAFI Ai, you can check its charge level by pressing the battery **Power** button:

| LED 1 | LED 2 | LED 3 | LED 4 | Charge Level |
|-------|-------|-------|-------|-------------------|
| | | | | 0 - 25% charged |
| | | | | 25 - 50% charged |
| | | | | 50 - 75% charged |
| | | | | 75 - 100% charged |

When the battery is installed on the drone and when ANAFI Ai is powered on, you can estimate your remaining flying time based on the number of steady LEDs:

| LED 1 | LED 2 | LED 3 | LED 4 | Remaining flight time |
|-------|-------|-------|-------|-----------------------|
| | | | | less than 8 minutes |
| | | | | 8-16 minutes |
| | | | | 16-24 minutes |
| | | | | 24-32 minutes |

Battery care and safety

ANAFI Ai's smart battery features a wintering mode, designed to increase its durability and facilitate its care. Ideally, when not in use for a prolonged period, batteries should be stored half-charged. When not in use for 10 days, ANAFI Ai's smart battery discharges itself, if required, to 65% charge, over a 48h period.

After a maximum of 12 days without use, the smart battery enters hibernation with a charge level which never exceeds 65%. If you leave your ANAFI Ai battery for 12 days, the **Power** button does not activate the charge level LED indicators. You must charge the battery to exit the wintering mode and start operating as described in the earlier paragraphs. This behavior preserves the battery over time.

TIP: always run a full charge of your smart battery before flying ANAFI Ai.

ANAFI Ai's smart battery must be handled, transported and stored with care:

- Do not store the battery long-term (1 month or more) with a charge level below 30%;
- Never leave the battery unattended while charging;
- Never expose the battery to extreme temperatures, neither hot, nor cold;
- Never leave the battery exposed to direct sunlight for prolonged periods of time;
- Never charge the battery when it is still warm from use (wait for at least 20 minutes);
- Never use or recharge a damaged or swollen battery;
- Always store your battery in a dry, ventilated environment, at a temperature close to 20°C;
- Always carry your battery in a fire-retardant bag or case (unless it is installed on ANAFI Ai: it can then be transported with the drone, inside its carrying case).

IMPORTANT: the ideal long-term storage conditions for the battery are:

- at room temperature 23°C +/- 2°C;
- at a relative humidity of 65% (rh) +/- 20%;

NOTE: ANAFI Ai's smart battery only charges in ambient temperatures between +10°C to +45°C. Flying time is reduced if you fly in temperatures approaching 0°C. The ideal operating temperature of the smart battery is 20°C. Ensuring that the smart battery remains as close as possible to 20°C before starting a flight minimizes the reduction in the smart battery's capacity in cold environments.

IMPORTANT: The core temperature of the battery must remain at 5°C or above to power the drone. If the temperature drops below 5°C, the battery cannot power on the drone.

TIP: You can use your body heat to maintain the temperature of the battery. Keep the battery in your pocket prior to flying in a cold environment.

If the behavior of your battery is not consistent with the information in this section, and if the battery does not power your ANAFI Ai, you must hard reset your battery. To perform a battery hard reset:

1. Plug the battery into a power source with the enclosed cable,
2. Press the battery's  **Power** button pressed for 15 seconds (regardless of the behavior of the LEDs) and then release the button.

The hard reset is successful if the battery's LEDs flash quickly, one after the other, alternating green and red.

Battery state of health

On the FreeFlight 7 homepage:

1. tap the **Drone information** tile
2. tap the **Battery** tile.

The **Battery information** screen opens and provides the status of the following battery characteristics:

- | | |
|--------------------------------|-------------------------------|
| - Individual cell voltage (mV) | - Total Capacity (mAH) |
| - Total Voltage (V) | - State of health (%) |
| - Temperature | - Cycles |
| - Serial number | |

Battery update

Before flying, you must systematically check for battery updates to ensure maximum performance and safety. Updates improve stability and performance of the complete system.

On the ANAFI Ai screen, tap the **Firmwares Battery** tile, the **battery update checklist** screen opens.

Before you start the update, ensure that:

- the battery power level is at 5%, or more. If required, charge the battery before starting the update.
- the USB-C cable is connected to the battery. You must use a USB Power Delivery charger to perform the update. Parrot recommends using the included USB power delivery charger.

Tap **Continue**.

CAUTION: Do not remove the battery during the update procedure.

The battery **Firmware update** screen opens and shows the firmware download progress. When the download is complete, the update is sent to the battery. The drone reboots at the end of the update, but does not shut down.



Firmware Update battery screen showing download progress

MicroSD card and media management

This section explains how to install a microSD card in ANAFI Ai and how to retrieve your media from the microSD card.

Installing a microSD card

The ANAFI Ai microSD card slot is located on the left-hand side of the drone. To install (or remove) a microSD card, you must open the SD cover.

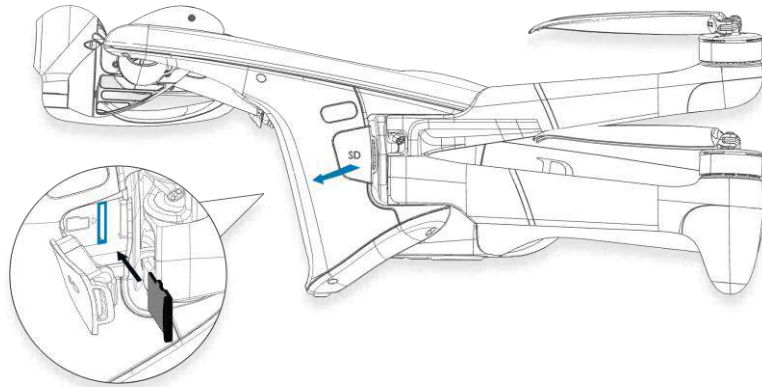

1. Open the SD cover to expose the microSD card slot.
2. Insert the microSD card into the keyed slot.

The microSD card makes a slight clicking sound.

IMPORTANT: In the correct orientation, the microSD card's metal contacts face toward the back of the drone. The shortest side of the microSD card faces toward the top of the drone. A **microSD-card-with-arrow** icon , located to the left of the microSD slot, confirms how you must insert the microSD card.

3. Close the SD cover.

Retrieving photos and videos

1. Remove the microSD card from the drone.
2. Insert the microSD card into the microSD card slot on your computer.

If your computer does not have a microSD card slot, you must use a microSD to SD card adapter.

3. Copy the videos and photos taken with ANAFI Ai to the computer hard drive to store, edit, and manage the media.

TIP: Parrot recommends you backup your photos and videos, and you empty your microSD card after each flight, to ensure you always have available memory space to capture new still or moving images.

Compatible microSD cards

Refer to Parrot's [online documentation](#) for an updated list of compatible microSD cards.

Direct media retrieval (drone to computer)

Alternatively, retrieve the media directly from ANAFI Ai, without extracting the microSD card.

Power the full system on and activate the **Direct connection from PC or smartphone** option from the **Developer** settings. Refer to the "[Settings / Advanced / Developer](#)" section for more information.

Use the enclosed USB-C to USB-C cable to connect the drone to the USB-C port of your PC (Windows OS computer).

If your computer does not have a USB-C port, you can use a USB-A to USB-C cable to connect ANAFI Ai to your computer.

ANAFI Ai mounts as an external drive. Copy your media from the **DCIM/100MEDIA** directory to your computer's hard drive.

When you finish managing your media, click **Safely Remove Hardware** in the Windows taskbar, then click **Eject ANAFI Ai**, like any other external drive.

NOTE: When plugged in to a computer and powered on, ANAFI Ai's battery discharges itself. You must recharge your smart battery after you retrieve your media, even if the battery was fully charged when you began the procedure.

FreeFlight 7 Medias gallery

You can access the **Medias** gallery from the FreeFlight 7 homescreen. Tap the **Medias** tile.

The **Medias** gallery has 2 tabs at the top of the interface; **Drone Memory**, and **Local Memory**.

NOTE: If ANAFI Ai is powered on and connected to the device (directly or through the Skycontroller 4), the FreeFlight 7 **Medias** gallery displays the microSD card media, by default.

Tap any media to preview it.

Tap any green media download box to transfer the corresponding media to your device.

Tap the **Local Memory** tab to access any media you download to your device.

The **Medias** gallery also lets you:

- preview videos and photos, without downloading them to your device;
- create panoramas (refer to the "[Videos, Photos and Panoramas / Creating Panoramas](#)" section for more information);
- format a microSD card;
- share media.

MicroSD card formatting

To format the microSD card:

1. Tap the **Drone Memory** tab,
2. Tap **Format SD Card**,
3. Select one of the following options:

| | |
|---|---------------------|
|  | Quick format |
|  | Full format |

Confirm your selection from the next screen to launch the formatting.

CAUTION: Both options delete all microSD card contents.

Introducing FreeFlight 7

The HUD (heads-up display) interface of FreeFlight 7 enables you to access all the features of ANAFI Ai, from your device's screen.

Presentation of the HUD



- | | |
|--|--|
| <ol style="list-style-type: none"> 1. < Back to homescreen 2. ⌚ Drone ground speed 3. 📏 Drone altitude relative to take-off point 4. 📏 Drone horizontal distance relative to pilot 5. 🛡️ Obstacle avoidance shield 6. 🧭 Compass and drone direction to pilot 7. 🔋 Controller battery & device GPS statuses 8. 📶 Drone: battery/4G/Wi-Fi/GPS statuses 9. ⚙️ Settings 10. Notifications & alerts zone | <ol style="list-style-type: none"> 11. Zoom factor 12. 📷 Gimbal tilt 13. 😊 MISSIONS modes 14. Drone speed mode (Film/Sport) 15. Photo/Video MODE 16. Image settings 17. Soft Shutter (Record/Stop: video mode) 18. Slider 19. 📍 Center (drone/controller) toggle 20. Map/3D view area |
|--|--|

| Missions | Imaging modes |
|------------------|---------------|
| ☺ Piloting | 📹 Video |
| 📷 Photogrammetry | 📷 Photo |
| 📍 Flight Plan | 🕒 Timelapse |
| 📷 Cameraman | 📷 GPS lapse |
| 🚗 Vehicle | 🗺️ Panorama |
| 📍 Touch & Fly | 📷 Bracketing |
| | 📷 Burst |

TIP: Ensure that both GPS icons are green (and not red) before you make ANAFI Ai take off. This means that your device and ANAFI Ai are both synchronized to enough GPS, GLONASS, and Galileo satellites to optimize the stability of the drone, especially at higher altitudes.

HUD Slider Management

The slider separates the video feed from the map, or 3D view. You can configure the screen to your personal preferences, or to the specifics of your mission.

Touch the slider, seen in the red box in the figure below, and slide it to the left to increase the map size or 3D view. Slide it to the right to decrease the map size or 3D view.

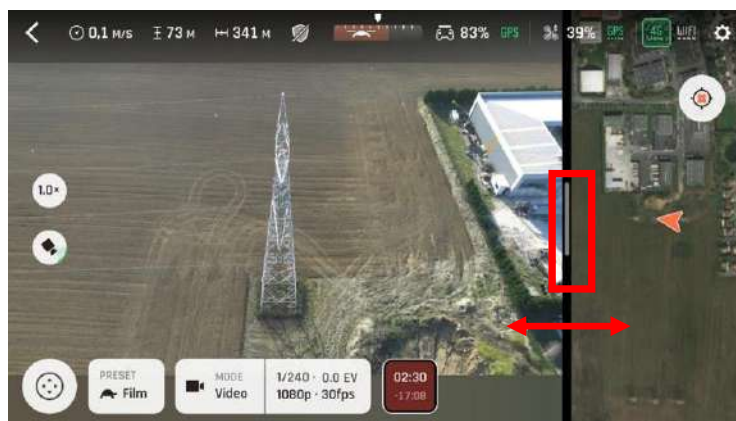

Slider default view. Touch the slider and move to adjust the map size

NOTE: On larger devices (tablets), the map is displayed on the lower part of the screen.

Settings

Tap **Settings** to access the **Quick**, **Controls**, and **Advanced** tabs.

Quick

The **Quick** tab is selected by default. There are 6 tiles displayed: **Map**, **Obstacle avoidance**, **Audio**, **Geocage**, **Lossless zoom only**, and **Auto-record**.

Tap the **Map** tile to toggle between the map view and the 3D view. Tap the **Obstacle avoidance**, **Audio**, **Geocage**, **Lossless zoom only**, and **Auto-record** tiles to activate or deactivate the setting.

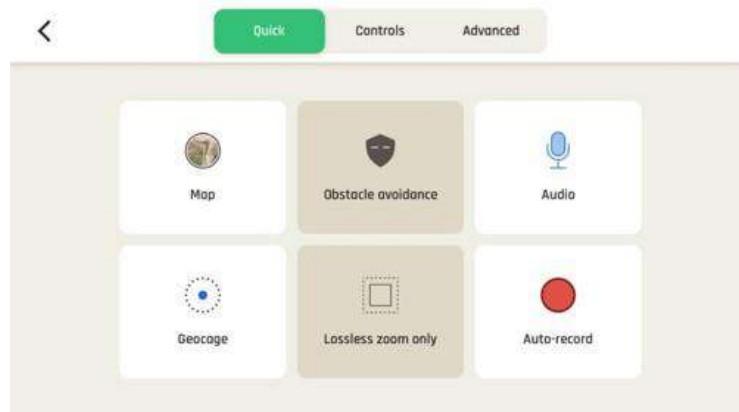

Quick settings interface

Controls

Controls settings manage the way your controller behaves. Tap an option to select it.

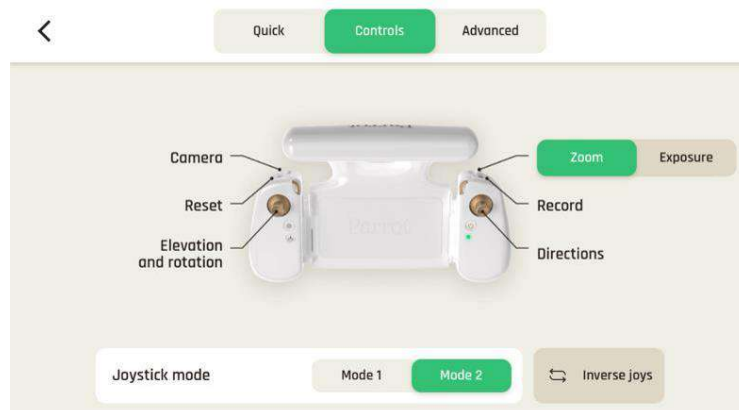

Controls settings interface



Advanced



Tap the **Advanced** tab on the top menu bar to open the advanced settings interface. The advanced settings menu opens with options on the left-hand side of the screen. Tap the appropriate option to customize values for:

-  **Presets**
-  **Interface**
-  **Flight area**
-  **RTH**
-  **Recording**
-  **Connection**
-  **Certificate**
-  **Developer**

Default values (DV) are displayed in bold characters or highlighted on screenshots. Use the sliders, or toggle buttons on the screen to customize the values. Tap the reset button on the bottom of each page to reset the corresponding mode to its default values.

Presets

The Presets settings allow you to adapt the behavior of ANAFI Ai for each mode. Select either the  **Film** mode or  **Sport** mode tab.

| | |
|---|---|
|  Gimbal | |
| Camera tilt speed | 1°/s to 180°/s (DV: 10°/s for FILM; 35°/s for SPORT) |
|  Flight | |
| Banked turn | NO / YES (DV: YES for FILM, NO for SPORT) |
| Inclination | 0.25°/s to 30°/s (DV: 10°/s for FILM; 25°/s for SPORT) |
| Vertical speed | 0.05 m/s to 4 m/s (DV: 1 m/s for FILM; 4 m/s for SPORT) |
| Rotation speed | 10°/s to 200°/s (DV: 10°/s for FILM; 90°/s for SPORT) |

CAUTION: **Inclination** and **Vertical speed** values have the biggest impact on ANAFI Ai's acceleration and general flying behavior. Higher settings require extreme care, superior piloting skills, or both, when flying ANAFI Ai.

Interface

The interface menu allows you to customize what you see on the device screen while you fly the drone. You can customize the following options:

| | |
|---------------------------|-------------------------------|
| Map type | Plan/Satellite/ Hybrid |
| Measurement system | Auto /Metric/Imperial |
| Display grid | No/ 3x3 /6x6 |

You can add a grid overlay to the streaming view.

Tap **RESET INTERFACE SETTINGS** on the bottom of the page to reset to the default values.

Flight area

The flight area interface allows you to customize the geocage boundaries, and activate or deactivate geowareness.

Geocage

The **geocage** feature allows you to set distance and height boundaries for ANAFI Ai. **Geocage** is activated by default. You can customize the following settings:

| | |
|-------------------------|--|
| Activate geocage | No/ Yes |
| Max distance | configurable from 10 m to 4 km (100 m default) |
| Max altitude | configurable from 1 m to 150 m (100 m default) |

When the **Geocage** is activated, FreeFlight 7 displays an alert, **Geocage reached**, when the drone approaches the set limit. The drone stops when it reaches the set limits, as in the screenshot below.



Geocage limit reached

NOTE: If the drone disconnects from FreeFlight 7 at takeoff, or during flight, the **Geocage** activates automatically with the following parameters:

- Altitude - 120m (C1 regulation)
- Distance - 4000m

If the drone disconnects when it is above 120m, the drone cannot ascend.

Geoawareness

The geo-awareness function detects potential airspace boundary violations and alerts the pilot remotely. This feature is designed to help you respect European regulations. As a drone pilot, you must respect the geographical flight limits in place in the country where you fly.

The geo-awareness function alerts the pilot when:

- The drone is about to enter a restricted airspace, or
- The drone is in a restricted airspace.

Examples of restricted areas can include, airports, prisons, government facilities, or other sensitive areas, etc.

NOTE: Geographical data on restricted areas is managed by Parrot and is updated regularly without the need for user intervention.

Geo-awareness is enabled by default. You can deactivate it in the advanced settings.

WARNING: It is the pilot's responsibility to respect restricted airspace.

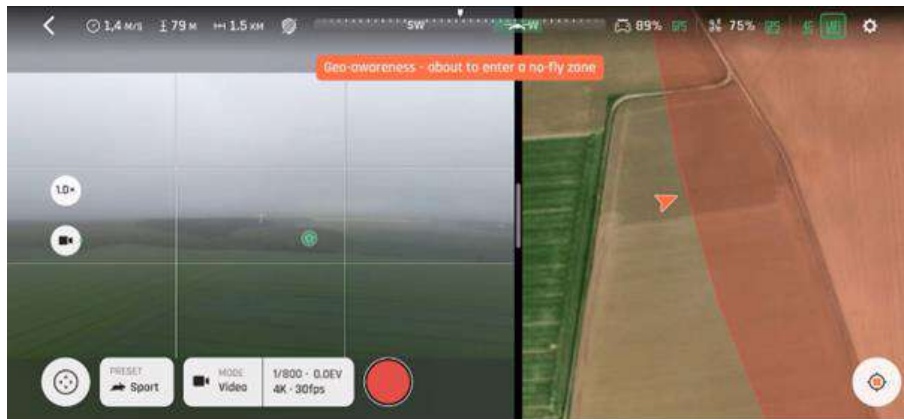

Warning: Geo-awareness - about to enter a no-fly zone

When the geo-awareness function is activated, the alert: **Geo-awareness – about to enter a no-fly zone** appears on the screen in orange, if you are about to enter a restricted area. The alert appears 10 seconds before you enter the area, estimating your course if you maintain the same heading and speed.

If the drone is inside a restricted area, the orange alert is replaced by: **Geo-awareness – no-fly zone** in red.

The geo-awareness function indicates restricted areas but does not exempt you from being alert to your environment. For safety reasons, do not fly near airports, highways, train stations, railroads, city centers and other sensitive areas.

CAUTION: if the drone's GPS or magnetometer is unavailable, the geo-awareness function will be inoperative.

NOTE: some areas have vertical limits. The altitude of the drone being calculated in relation to the take-off point and not in relation to the ground, it is possible that a difference is present between the announced limit and the real limit. Take precautions when flying in areas of high terrain: the pilot remains responsible for respecting the vertical limits of the drone geographical zones.

Tap **RESET ALL GEO SETTINGS** on the bottom of the page to reset to the default values.

RTH

Through RTH settings, you define the behavior of your drone when the RTH feature is activated. You can customize the following options:

| | |
|-------------------|---|
| Return to | Take-off point /Pilot position |
| End by | Hovering /Landing |
| Hovering | horizontal slider configurable between 1m and 10m (2m default value) |
| RTH height | vertical slider configurable between 20m and 100m (50m default value) |

Tap **RESET RTH PREFERENCES** on the bottom of the page to reset to the default values.

The RTH can be used automatically if the weather is frosty, foggy, or if the battery is disconnected.

Recording

Recording settings enable you to select camera options, both in photo and video modes.

| | |
|-----------------------------|-----------------------------|
| Display overexposure | No/Yes |
| Sign pictures | No/Yes |
| Video encoding | H.264/ H.265 |
| Video HDR mode | HDR8/ HDR10 |
| Anti-flickering | Off/Auto/50 Hz/60 Hz |

When **Display overexposure** is activated, the HUD of FreeFlight 7 shows all overexposed areas of the screen as hatched, which enables you to fine-tune your framing, your EV settings, or both.

Sign pictures allows authentication and proof of integrity of files produced by ANAFI Ai (to serve as evidence, for example), but it can increase the achievable time interval between photos in **Timelapse** and **GPS-lapse** modes. When this feature is activated, a .sig file is recorded simultaneously with each picture taken.

Anti-flickering and the associated technology attempts to eliminate the flicker effect which can arise due to some artificial lights. The **AUTO** option should work for most users, but depending on your country, you can try other settings if you feel bothered by a flicker effect on your device's screen, your artificial light videos, or both.

Tap **RESET CAMERA SETTINGS** on the bottom of the page to reset to default.

Connection

Connection settings let you manage your 4G connection, change your ANAFI Ai's **Wi-Fi network name**, **PASSWORD** & band, and broadcast your **DRI**.

| | |
|---------------------------|-----------------------|
| Cellular data | |
| Cellular access | Off/On |
| Network preference | 4G/Wi-Fi/ Auto |
| APN selection | Manual/ Auto |

The **Auto** (default) option in **Network preference** lets the drone manage its connections.

Wi-Fi

| | |
|---------------------------|--|
| Wi-Fi network name | Type network name in the field, then tap PASSWORD |
| Wi-Fi channel | Manual/ Auto |
| Broadcast DRI | No/ Yes |

Use other options to adapt to your flight conditions. **4G** priority relies on the 4G network as long as it is available, before switching to **Wi-Fi**; **Wi-Fi** priority relies on the **Wi-Fi** connection as long as it is available, before switching to **4G**.

IMPORTANT: **4G** connection and in flight **4G** data sharing may generate a charge, according to the **4G** data plan associated to your nano SIM card.

While flying without **4G** connection in dense environments such as cities, we recommend switching to **Manual** Wi-Fi channel and use UNII3 5GHz band (channel 149 to 161) if it's available in your country.

Tap **PASSWORD** to define the Wi-Fi key shared by ANAFI Ai and the Skycontroller 4. Parrot defines a unique random password for each ANAFI Ai and Skycontroller 4 package, but Parrot highly recommends you define your own password. Your password must be robust: 10 characters long or more and using at

least 3 types of characters among uppercase, lowercase, digits, and special characters. The security of your ecosystem and data depends on the security of this password.

The **Direct Remote Identification (DRI)** option ensures, in real time, the local broadcast of remote pilot (operator registration number) and drone information (such as the serial number) during the flight. The **DRI** electronic signal is compliant with both European & American drone regulations.

According to European for open category or American drone regulation, ensure that the **DRI** function is activated during in-flight operation by tapping **Yes**. For additional information, consult the regulations in force.

IMPORTANT: It is your responsibility, as an ANAFI Ai owner, operator, or both, to check your local authorities' requirements before you fly.

Tap **RESET WI-FI PREFERENCES** on the bottom of the page to reset to default. FreeFlight 7 must be connected to ANAFI Ai for this button to appear.

Developer

Developer settings allow you to access debug tools for AirSDK mission developers. You can customize the following options:

| | |
|--|---------------|
| Direct connection from PC or smartphone | No/Yes |
| Shell access | No/Yes |
| Activate AirSDK missions logs | No/Yes |

Shell access and **Activate AirSDK missions logs** cannot be modified by default. You must activate **Direct connection from PC or smartphone** to activate ANAFI Ai shell access and custom mission logs.

Videos, Photos, and Panoramas

ANAFI Ai is equipped with a 3-axis-stabilized camera, which is capable of motion and still pictures, through a 1/2" CMOS 48MP sensor. The lens of the camera includes low dispersion aspherical elements, that reduce chromatic aberrations and flare. FreeFlight 7 has multiple configurable settings, from full auto to manual professional options.

TIP: You can film and take pictures using your device as ANAFI Ai's controller. However, Parrot recommends that you always use the Skycontroller 4 and your device, for the best flight experience.

Making videos

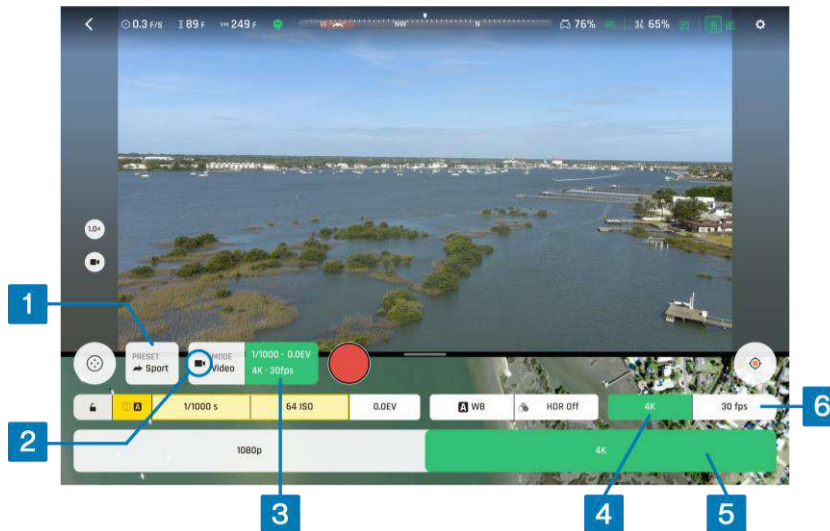

Video options - MODE options not shown, 4k with 30 fps

To access ANAFI Ai's video options:

1. Tap the **MODE** box in the bottom bar of the HUD,
2. Tap the **Video** mode box from the mode menu (mode menu not shown on the screenshot).
3. Tap the **Image settings** box to open the video settings menu
4. Tap the **Resolution** box
5. Select **1080p**, or **4k** from the **Resolution menu** (4k resolution in screenshot)
6. Tap the **Framerate** box to select the fps value (30 fps in screenshot)
7. Tap the **Image settings** box again to close the sub-boxes and confirm your choices.

Available fps values depend on the resolution you select, and on whether you activate the HDR option:

| | |
|---------------------|--|
| 4K: | 24 fps, 25 fps, or 30 fps |
| 4K HDR: | 24 fps, 25 fps, or 30 fps |
| P-Log 4K: | 24 fps, 25 fps, or 30 fps |
| 1080p: | 24 fps, 25 fps, 30 fps, 48 fps, 50 fps, or 60 fps |
| 1080p HDR: | 24 fps, 25 fps, or 30 fps |
| P-Log 1080p: | 24 fps, 25 fps, 30 fps, 48 fps, 50 fps, or 60fps |

Press the Skycontroller 4's **Media recording** button (or tap the HUD's **Soft shutter** button) to start filming.

The round **soft shutter** button of the HUD turns into a square and displays a double timer. It shows the time since the video started (main timer, top) and remaining filming time (small timer, bottom).

Press the **Media recording** button (or tap the **Soft shutter** button) again to end the recording. The HUD's **soft shutter** button returns to steady red, and round. The timer disappears.

Taking photos

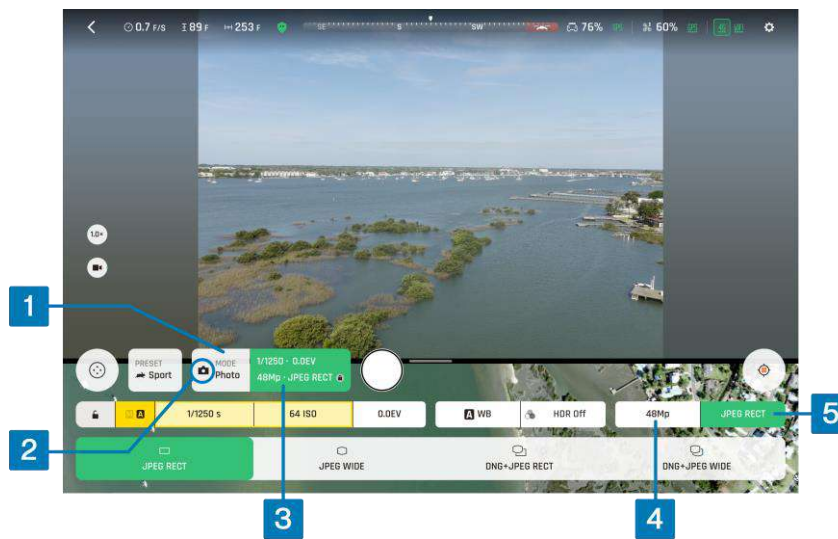

Photo options - MODE options not shown, 48 MP with JPEG RECT

To access ANAFI Ai's photo options:

1. Tap the **MODE** box in the bottom bar of the HUD.
2. Tap a photo mode from the corresponding menu of the HUD (mode menu is not shown on the screenshot, **Photo** mode is selected).

6 photo modes are available on ANAFI Ai:

| | |
|-------------------|---|
| Photo | JPEG RECT, JPEG WIDE, DNG+JPEG (RECT or WIDE) |
| Timelapse | JPEG RECT only |
| GPS Lapse | JPEG RECT only |
| Panorama | JPEG RECT only |
| Bracketing | JPEG RECT, JPEG WIDE, DNG+JPEG (RECT or WIDE) |
| Burst | JPEG RECT, JPEG WIDE |

NOTE: The HDR option is only available for 12MP JPEG photos.

3. Tap the **Image settings** box to open the photo settings menu.
4. Tap the **Resolution** box, select **12MP** or **48MP** (Screenshot shows 48MP resolution is selected).
5. Tap the **Photo formats** box.

ANAFI Ai photo formats:

| | |
|-----------------------|--|
| JPEG RECT: | 4:3 aspect ratio, 12 MP or 48 MP, 64° HFOV (<i>Horizontal Field Of View</i>) |
| JPEG WIDE: | 4:3 aspect ratio, 48 MP, 73° HFOV – zoom is disabled for this format |
| DNG+JPEG RECT: | 4:3 aspect ratio, 48 MP, 73° HFOV |
| DNG+JPEG WIDE: | 4:3 aspect ratio, 48 MP, 73° HFOV – zoom is disabled for this format |

6. Tap a format (**JPEG RECT**, or **JPEG WIDE** if available, or any **DNG+JPEG** format if available) to select it.
7. Tap the **Image settings** box again to close the sub-boxes and confirm your choice.

NOTE: The **DNG+JPEG** option produces at least 2 files: 1 DNG (*Digital NeGative*) and 1 JPEG, for each shutter action. DNG is a RAW format. RAW formats retain all the information gathered by photography sensors, contrary to JPEG formats which are compressed and processed renderings of this comprehensive information. As a result, RAW pictures such as DNG images are heavy files, but they provide the best post-processing and retouching possibilities.

When you select a photo mode, the HUD **Soft shutter** button appears as a full white circle.

 **Photo** mode has no options. It takes 1 photo each time you press the shutter. The screen flashes black and white to confirm a picture has been taken.

 **Timelapse** mode has 7 options: **0.5s** (12MP only), **1s**, **2s**, **4s**, **10s**, **30s**, and **60s**. The screen flashes black and white to confirm a picture has been taken. The drone continues to take photos every 0.5 to 60 seconds, depending on your option choice, until you press the shutter button again to stop the timelapse.

 **GPS Lapse** mode has 9 options: **0.5 m**, **1 m**, **2 m**, **5 m**, **10 m**, **20 m**, **50 m**, **100 m**, and **200 m**. The screen flashes black and white to confirm a picture has been taken. The drone continues to take photos when it reaches any point on a 0.5 to 200 meter radius sphere around the initial photo, depending on your option choice, until you press the shutter button again to stop the GPS Lapse. Between each shutter action, a green progress bar, at the bottom of the HUD, lets you estimate the distance the drone must cover before the next shot.

 **Panorama** mode has 4 options: **Vertical**, **Horizontal**, **360**, and **Super Wide**.

 **Bracketing** mode has 3 options: **3 photos** (-1 EV, +0.0 EV, +1 EV), **5 photos** (2 EV to +2 EV) and **7 photos** (-3 EV to +3 EV). When you select an option, the HUD **Soft shutter** button displays the number of the corresponding option. The screen flashes black and white to confirm 3, 5 or 7 pictures have been taken.

 **Burst** mode has no options. It takes 10 photos in the span of 1 second each time you press the shutter. The screen flashes black and white to confirm 10 pictures have been taken.

Creating Panoramas

ANAFI Ai panoramas are generated automatically through the FreeFlight 7 gallery, based on a series of pictures taken by the drone.

NOTE: ANAFI Ai cannot proceed with a panorama if the drone battery power is low (capturing a 360 Panorama takes ANAFI Ai 85 seconds).

The generation of a panorama, regardless of its format, has 3 phases:

- collecting the pictures, in flight (except for the **Super Wide** format, which can be shot with a landed drone);
- downloading the pictures from ANAFI Ai to your device;
- stitching the pictures together to create the panorama, in the FreeFlight 7 gallery.

Before shooting a panorama:

1. Ensure you are not flying lower than 10 meters (30 ft) over water.
2. Ensure no object or subject is present in a 10-meter (30 ft) radius around ANAFI Ai. This optimizes the stitching process.

NOTE: ANAFI Ai locks the exposure of the frame with which you start your panorama. For this reason, Parrot recommends you always frame the main subject of the intended panorama before pressing the shutter button. Refer to the “[Advanced imaging / Lock AE](#)” section for more information.

To capture a panorama, tap the **MODE** box, then tap the **Panorama** box in the HUD. There are 4 panorama formats:

Panorama types capture characteristics

| | |
|---------------------|--|
| 📏 Vertical | ANAFI Ai takes 8 photos in approximately 20 seconds |
| 📏 Horizontal | ANAFI Ai takes 10 photos in approximately 20 seconds |
| 🌐 360 | ANAFI Ai takes 38 photos in approximately 96 seconds |
| 📏 Super Wide | ANAFI Ai takes 9 photos in approximately 18 seconds |

NOTE: **Vertical**, **Horizontal** and **360 panoramas** require the drone to be flying before you can activate the shutter.

Press **Media recording** on Skycontroller 4 (or tap the HUD’s **Soft shutter** button) to begin the Panorama capture. ANAFI Ai starts taking pictures and the bottom of the HUD displays a progress bar which fills with green as the capture unfolds.

To download the Panorama pictures to your device, land ANAFI Ai. Then, from the FreeFlight 7 homepage, tap the **Medias** tile to access the **Gallery**. Like other medias, Panoramas are marked with their distinct icon and a green download box, which shows the size of the corresponding series of pictures. The icon boxes at the top center of the screen enable you to filter your media.

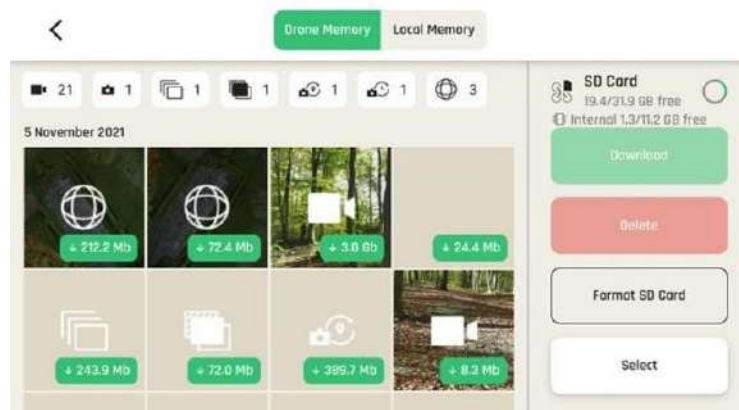

Drone Memory displaying panoramas

Tap the green box of the panorama you want to generate to start downloading the corresponding series of pictures to your device. When the download is complete, FreeFlight 7 displays a page from where you can delete the downloaded photos. Tap **Keep**, to keep the originals on the microSD card. Tap **Delete** to delete them.

Tap the **Local Memory** tab to access the device gallery, which contains only the media you download from ANAFI Ai’s microSD card.

Finally, select the panorama you want to generate from your local gallery. FreeFlight 7 displays the following screen.

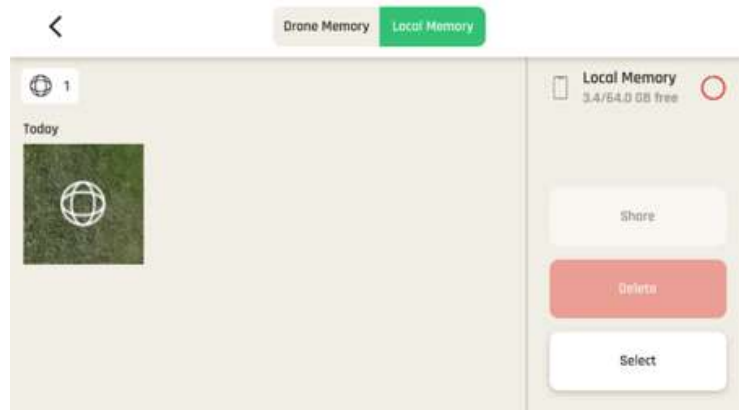

Local Memory (device) displaying a Panorama

Tap **Generate Panorama** to create the panorama (or browse the individual pictures with the slider on the right). When the panorama creation is complete, FreeFlight 7 displays the result.



Generate Panorama interface

Media Metadata

ANAFI Ai photos and videos contain metadata with the drone telemetry elements (position, altitude, speed, battery level, etc.) and video metrics (angle of the camera, exposure value, field of view, etc.).

The altitude in the photo metadata is based on WGS84 whereas the altitude displayed on FreeFlight 7 is the altitude above takeoff. Because of that, both values might differ depending on the take-off location.

You can learn more about the embedded photo Metadata [here](#), and more about embedded video Metadata [here](#).

Gimbal tilt control

ANAFI Ai features a controllable gimbal (180° tilt range, nadir to zenith). Gimbal tilt is controlled with Skycontroller 4's **Gimbal tilt** trigger (left trigger). It is available in all video and photo modes, and in all manual piloting modes.

- To aim the gimbal toward the ground, push the **Gimbal tilt** trigger down.
- To aim the gimbal toward the sky, pull the **Gimbal tilt** trigger up.
- To reset the gimbal tilt to a horizontal position, press  **Optics reset** button.

Zoom control

ANAFI Ai features a 6x zoom. Zoom is controlled with Skycontroller 4's **Zoom** trigger (right trigger). It is available in all video modes, and in **JPEG RECT** photo mode (with an impact on the final resolution of your pictures). **WIDE** photo modes imply the use and rendering of all 48MP delivered by ANAFI Ai's CMOS sensor. Zoom is deactivated in both **WIDE** photo modes.

- To zoom in on a subject, push the **Zoom** trigger down.
- To zoom out, pull the **Zoom** trigger up.
- To reset the zoom factor to 1x, press the  **Optics reset** button

FreeFlight 7's HUD presents precise, decimal-by-decimal zoom information at all times, in the middle of the left-hand side of the screen.

ANAFI Ai presents no lossless zoom capabilities for pictures. The zoom is deactivated by design in **WIDE** formats (**JPEG** and **DNG+JPEG**), and it has an impact on the resolution of the pictures in **JPEG RECT** format.

By contrast, ANAFI Ai offers lossless zoom capabilities for 1080p (4x) and 4K (2x) videos. The 1080p video mode offers the best resolution for direct observation, even out of the lossless zoom envelope.









1080p 1x zoom



1080p 6x max zoom

The following table shows the zoom level correlation depending on each photo and video mode:

| Mode | Media format | Lossless zoom off | Lossless zoom on |
|---|-------------------------|-------------------|------------------|
|  Video | 4k (std, HDR, P-Log) | Up to x6 | Up to x2 |
| | 1080p (std, HDR, P-Log) | Up to x6 | Up to x4 |
|  Photo | JPEG RECT | Up to x6 | Unavailable |
| | JPEG WIDE | Unavailable | Unavailable |
| | DNG+JPEG RECT | Up to x6 | Unavailable |
| | DNG+JPEG WIDE | Unavailable | Unavailable |
|  Timelapse | JPEG RECT | Unavailable | Unavailable |
|  GPS Lapse | JPEG RECT | Unavailable | Unavailable |
|  Panorama | JPEG RECT | Unavailable | Unavailable |
|  Bracketing | JPEG RECT | Up to x6 | Unavailable |
| | JPEG WIDE | Unavailable | Unavailable |
| | DNG+JPEG RECT | Up to x6 | Unavailable |
| | DNG+JPEG WIDE | Unavailable | Unavailable |
|  Burst | JPEG RECT | Up to x6 | Unavailable |
| | JPEG WIDE | Unavailable | Unavailable |

Advanced image settings

ANAFI Ai is set to deliver high quality and balanced 4K videos and 48MP photos, out of the box. However, there are multiple advanced image settings. This section is designed to help you exploit the manual settings.

To access the advanced image settings:

1. Tap the **Image settings** box in the HUD.
2. Tap **M A** to toggle between **Manual** mode and **Auto** mode.

Additional settings boxes are unlocked:

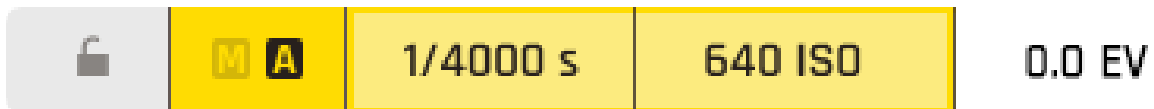



Figure 1: Manual/Auto toggle

NOTE: In **Auto** mode, the only setting accessible is Exposure value **EV**. If you attempt to change other values while in **Auto** mode, FreeFlight 7 switches to **Manual** mode.

| | |
|---|---|
|  | <p>Manual mode M: The pilot chooses the shutter speed s, and the ISO. (Shutter speed box and ISO box in gray). EV not accessible.</p> |
|  | <p>Auto mode A: ANAFI Ai chooses the shutter speed s, and the ISO value based on the surroundings. (Shutter speed box and ISO box in yellow)</p> |

Lock AE

FreeFlight 7 allows the pilot to lock the general exposure of a view, to fine-tune the framing of a shot and keep the desired exposure.

The Open lock icon is on the far left of the **Image settings** menu.

Tap the **Open lock** icon to lock the exposure value to that of the current view. The icon turns into a **Closed lock** on a yellow background. A yellow **Lock AE** box appears in the **Notifications & Alert** zone, below the top bar of the HUD.

Move ANAFI Ai around or tilt its gimbal to change the frame. The exposure settings remain as they were when you activated the function.

Tap the **Closed lock** icon again to deactivate the exposure lock. The icon reverts to an **Open lock** on a white background.

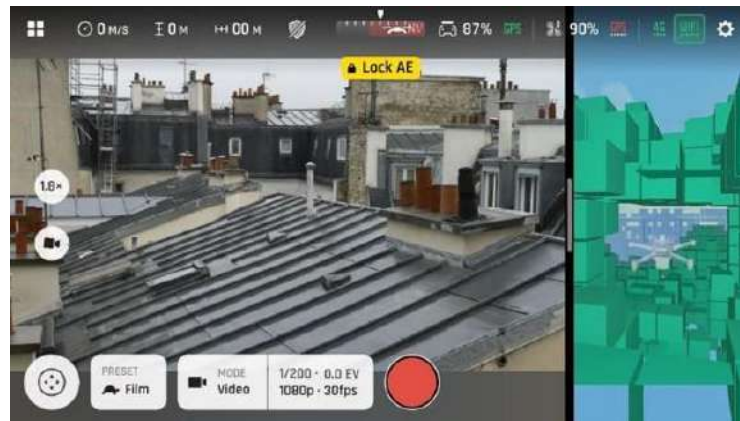

Lock AE activated

Lock AE Touch

With the **Lock AE Touch** (or **Spot AE**) function of FreeFlight 7, you can also lock the exposure of a frame on any detail of any view.

To activate this function, follow the **Lock AE** procedure of the preceding section. When the exposure is locked, long press the region of the frame you want to base your exposure on. A yellow square animates around this spot and the settings change (s value, ISO value, or both).

Refer to the following screenshots for additional details on the logic of this feature.

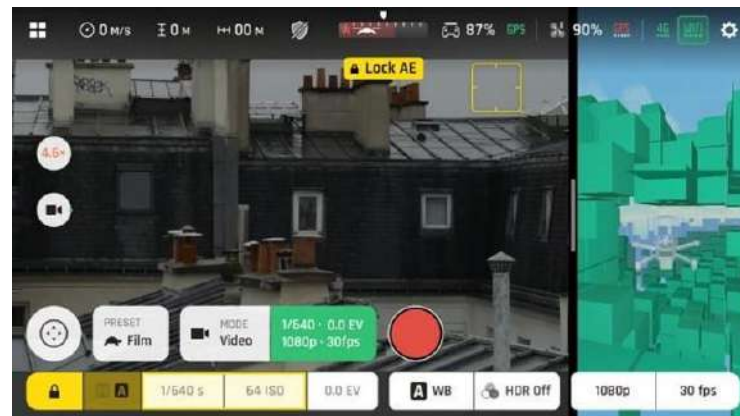

Exposure is locked on a white sky: shutter speed is set at 1/640 s and the image is underexposed

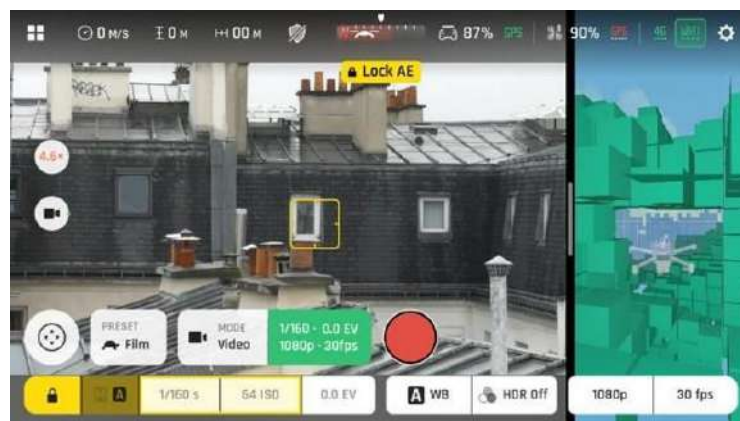

Exposure is locked on a building: shutter speed is set at 1/160 s and the image is correctly exposed

Shutter speed (s)

The **s** value refers to the exposure time, in fractions of a second, where the shutter stays open to capture a still picture.

In **Auto** mode, ANAFI Ai selects the best shutter speed and ISO value couple, in real time, depending on the scene and available light. As a result, selecting a shutter speed also deactivates the **Auto ISO** mode.

As ANAFI Ai's f/2.0 aperture lens lets in a lot of light, even compared to most professional SLR lenses, your drone can achieve very fast **s** values (down to 1/10000s) and capture very fast action. It can also be used for slow shots, up to 1/15 second for the photo mode.

NOTE: ANAFI Ai can shoot pictures and videos when it is not flying. You can hold it in your hand and use it as a stabilized 4K video and photo camera.

Tap the **s** box to open the shutter slider.

Select a value to exit the **Auto** mode for shutter speed and ISO. This action also deactivates the EV slider.

Set the desired **s** value, then tap the **ISO** box to select an ISO value. The HUD reflects the chosen settings. If you get lost, tap **Auto** either on the **s** or the **ISO** slider to get back to **Auto exposure** and reactivate the EV slider.

ISO value (ISO)

The ISO value refers to the sensitivity of the sensor. The ISO value is linked to the shutter speed value. Both sliders activate when you deactivate **Auto** mode and set a value for one, or the other. The lower the ISO value, the lower the sensitivity of the sensor, and the lower the image noise (digital grain). Therefore, under good lighting conditions, such as sunny daylight outside shots, select low ISO values (for example, between 50 and 200). 1600 ISO can be used to capture low light interior scenes, or exterior shots at dusk or dawn, for example.

By default, in **Auto** mode, ANAFI Ai constantly adapts its ISO and shutter speed values to the scene it is filming. However, setting an ISO value for a whole shot or series of shots is advised for professional filming.

Tap the **ISO** box to open the ISO slider.

Select a value to exit the **Auto** mode for ISO and shutter speed. This action also deactivates the EV slider.

Set the desired ISO value, then tap the **s** box to select a shutter value. The HUD reflects the chosen settings. If you get lost, tap **Auto** either on the **s** or the **ISO** slider to get back to auto exposure and reactivate the EV slider.

Exposure value (EV)

The EV expresses the general darkness or lightness of a photograph, or a video. At +0.0 (zero) EV, ANAFI Ai automatically adapts the shutter speed and the ISO value to deliver a perfectly balanced photo or video: not too dark and not too light.

Tap the **+0.0 EV** box to activate the **EV** slider.

Slide your finger on the screen to the negative values on the left to darken your picture or video. Slide your finger on the screen to the positive values on the right to lighten your picture or video.

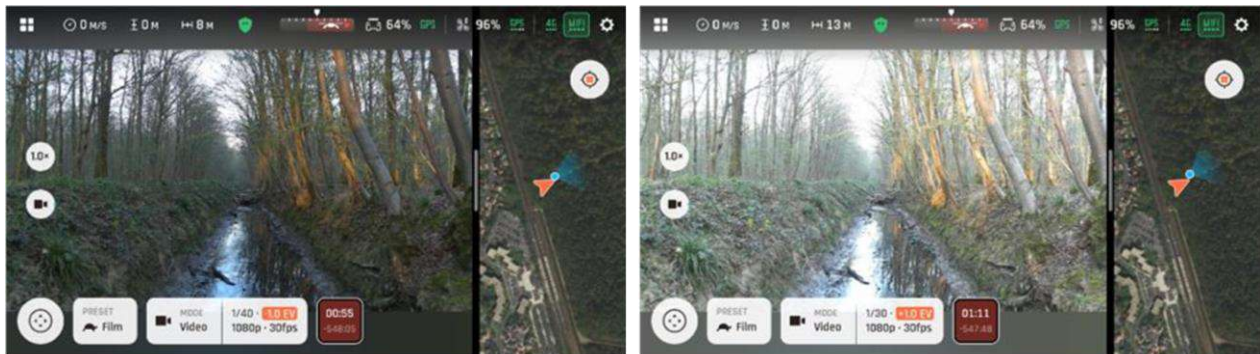

-1.0 EV (left image). +1.0 EV (right image)

White balance (WB)

White balance refers to the process of adjusting the colors in an image to accurately represent how they would appear under different lighting conditions, particularly in relation to the color temperature of the light source. Cold lights make whites look blue. Warm lights make whites look yellow. By default, in **Auto WB** mode, ANAFI Ai ensures that white objects appear neutral white, at all times. It adapts its WB value in real time.

However, setting a WB value for an entire shot is advised for professional filming. Stable WB facilitates the grading (color treatment) of videos.

Tap the **WB** box to open the white balance options.

Select the **WB** option that is best suited for your shooting conditions, your subject, or both. The display of the HUD reflects your settings and helps you make the best choice.



WB 2 000 K



WB 10 000 K



Auto WB



Incandescent WB



Fluo WB



Sunny WB



Cloudy WB



Shaded WB

HDR

HDR (high dynamic range) can enhance a video or a photo. The HDR option is available for videos (no lossless zoom and limited to 30 fps max in 4K, lossless zoom limited to 2x and limited to 30 fps max in 1080 p) and 12MP photos.

To activate the HDR option, tap the **Photos settings** box from the lower bar of the HUD, then tap the **HDR** box.

Tap **HDR On**. A HDR notice appears in black inside a yellow box, at the center of the top of the HUD. Press the **hard shutter** button on your Skycontroller 4 (or tap the **soft shutter** button of the HUD) to start filming in HDR or to take an HDR photo.

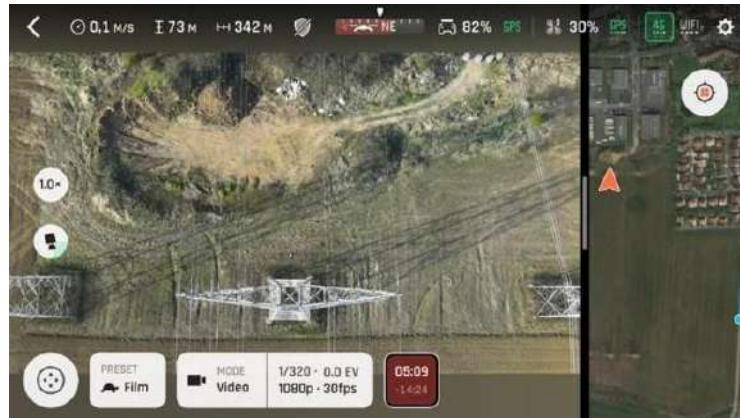

HDR off

Follow the same procedure and select **HDR Off** to revert.



HDR on

NOTE: You cannot modify, **s**, **ISO**, or **EV** values when the HDR mode is activated. However, you always keep control over your white balance (**WB**). Activating (or deactivating) HDR stops any ongoing video recording. A new recording with the new setting starts after 5 seconds.

ANAFI Ai features 2 HDR options: HDR-8 and HDR-10. HDR-10 is only available through H265 video encoding. Refer to the "[Settings / Advanced / Recording](#)" section for more information.

P-Log

P-Log style is also available through the **HDR** box, for video mode only. This alternative imaging style reduces contrast and saturation. **P-Log** style is ideal for videos you want to edit and postprocess using professional grading tools and filters.



P-Log filming mode

Missions

ANAFI Ai features six different mission types.

To access the different missions, tap the **MISSIONS** icon in the bottom-left corner of the HUD of FreeFlight 7 to access the Missions.

Tap the required mission to select it. Each Mission is associated with a specific behavior, which the following sections describe.

Missions: Piloting

The Piloting Mission is ANAFI Ai's default Mission. It enables you to pilot the drone and fully control its camera tilt and zoom.

When you release the commands in Manual flight mode, ANAFI Ai hovers in position.

Missions: Photogrammetry

Photogrammetry is the science and technology of obtaining reliable information about physical objects and the environment through the process of recording, measuring and interpreting photographic images. One of the leaders of the field is PIX4D, which became a Parrot Group company in 2012.

ANAFI Ai and FreeFlight 7 utilize PIX4D technologies which enables existing PIX4D users to seamlessly link their drone to their PIX4D account. New users can use ANAFI Ai to discover PIX4D photogrammetry services, through three offered mapping missions.

There are 4 types of photogrammetry mapping missions: **Grid**, **Double grid**, **Orbit** and **1-Click**. This section describes the specifics of each mission, and how to program them.

IMPORTANT: Absolute altitude reference (AAR) is the default flight height setting for all missions. AAR is the height the drone flies above the relevant ground level. AAR height may be different from average mean sea level (AMSL).

In FreeFlight 7, in the **Missions** selection menu, tap **Photogrammetry** to launch a photogrammetry flight.

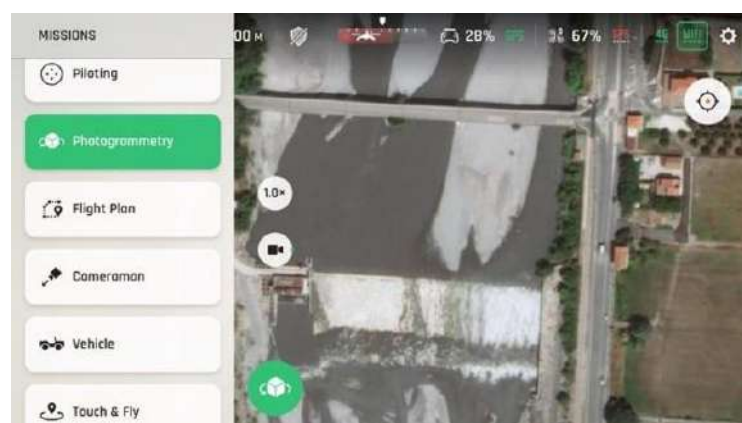

FreeFlight 7 MISSIONS selection menu

Grid

Simple grid photogrammetry flights create 2D maps. Simple grids can be precisely adapted to any shape, to match the borders of a field or a coastline, for example. Follow these steps to program and launch a simple grid mapping flight.

Tap the map to create a square grid.

Tap and slide the green corners of the square to adapt the grid to the zone you want to map. Tap any **+plus** sign to create a new segment and a new corner.

Tab box to select Image Parameters:

| | |
|---------------|------------------------------|
| Resolution | 12MP / 48MP |
| Exposure | -3.0 to +3/0 EV (DV: 0.0 EV) |
| White balance | Auto / Sunny / Cloudy |

Tap box to select Flight Parameters:

| | |
|-----------------------|----------------------------|
| 4G upload | Yes / No |
| Obstacle avoidance | Yes / No |
| Final RTH | Yes / No |
| RTH on data link loss | Yes / No |
| Altitude | From 5 m (DV: 50 m) |
| Camera tilt | -90° to 0.0° |
| Front overlap | 20.0% to 90.0% (DV: 80.0%) |
| Side overlap | 20.0% to 90.0% (DV: 60.0%) |

When you finish mapping the grid, tap **Done**.

Tap **Play** to launch the flight.

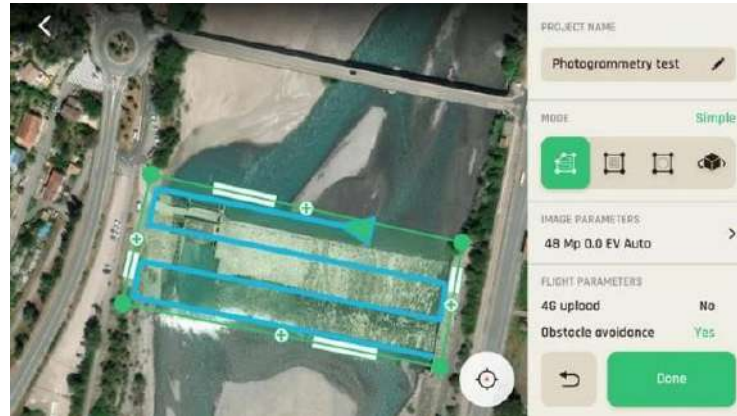

FreeFlight 7: Simple grid Photogrammetry

Double grid

Double grid photogrammetry flights create 3D maps or 3D models of square areas. Follow these steps to program and launch a double grid mapping flight.

Tap the map to create a square grid.

Tap and slide the green corners of the square to adapt the grid to the zone you want to map.

Tab **box** to select Image Parameters:

| | |
|---------------|------------------------------|
| Resolution | 12MP / 48MP |
| Exposure | -3.0 to +3/0 EV (DV: 0.0 EV) |
| White balance | Auto / Sunny / Cloudy |

Tap **box** to select Flight Parameters:

| | |
|-----------------------|----------------------------|
| 4G upload | Yes / No |
| Obstacle avoidance | Yes / No |
| Final RTH | Yes / No |
| RTH on data link loss | Yes / No |
| Altitude | From 5 m (DV: 50 m) |
| Camera tilt | -90° to 0.0° (DV: -70°) |
| Front overlap | 20.0% to 90.0% (DV: 80.0%) |
| Side overlap | 20.0% to 90.0% (DV: 60.0%) |

When you finish mapping the grid, tap **Done**.

Tap **Play** to launch the flight.

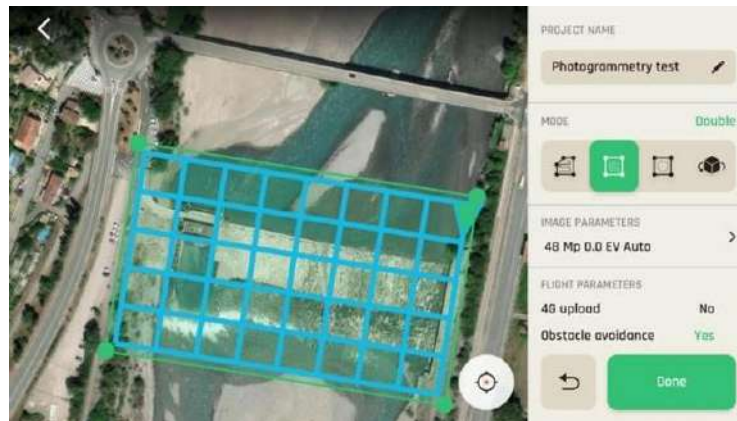

FreeFlight 7 **Double** Grid Photogrammetry

Orbit

Orbit photogrammetry flights can model an isolated building or structure in 3D. Follow these steps to program and launch a circular mapping flight.

Tap the map to create a square flight area.

Tap and slide the square to position the object you want to map at the center of the flight area.

Tap and slide the green corners of the square to adapt the flight area to the part surrounding the target object you want included in the 3D model.

Tap **box** to select Image Parameters:

| | |
|---------------|------------------------------|
| Resolution | 12MP / 48MP |
| Exposure | -3.0 to +3/0 EV (DV: 0.0 EV) |
| White balance | Auto / Sunny / Cloudy |

Tap **box** to select Flight Parameters:

| | |
|-----------------------|----------|
| 4G upload | Yes / No |
| Obstacle avoidance | Yes / No |
| Final RTH | Yes / No |
| RTH on data link loss | Yes / No |

| | |
|------------------|-------------------------|
| Altitude | From 5 m (DV: 50 m) |
| Number of photos | 18 to 90 |
| Camera tilt | -90% to 0.0° (DV: -45°) |

When you finish mapping the grid, tap **Done**.

Tap **Play** to launch the flight.

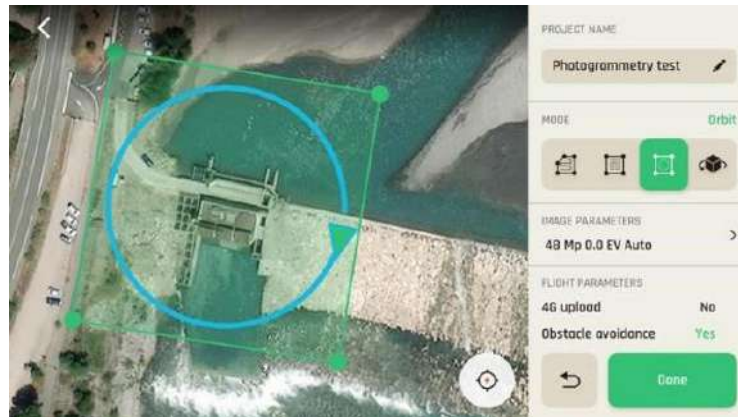

FreeFlight 7 Orbit Photogrammetry

NOTE: If the FreeFlight 7 device loses internet connection during the mission, the map may not be visible depending on the basemap tiles stored in the cache. However, the drone's path remains visible on the app.

1-Click

1-Click photogrammetry flights are designed to create the 3D model of a single building, with a single tap on the screen.

Tap the box which appeared on the map over the building you want to model. The box turns green.

Define Building height if it is unknown by the land register.

Tap box to select Image Parameters:

| | |
|---------------|------------------------------|
| Resolution | 12MP / 48MP |
| Exposure | -3.0 to +3/0 EV (DV: 0.0 EV) |
| White balance | Auto / Sunny / Cloudy |

Tap box to select Flight Parameters:

| | |
|-----------------------|---------------------|
| 4G upload | Yes / No |
| Obstacle avoidance | Yes / No |
| Final RTH | Yes / No |
| RTH on data link loss | Yes / No |
| Building height | From 5 m (DV: 10 m) |

When you finish mapping the grid, tap **Done**.

Tap **Play** to launch the flight.

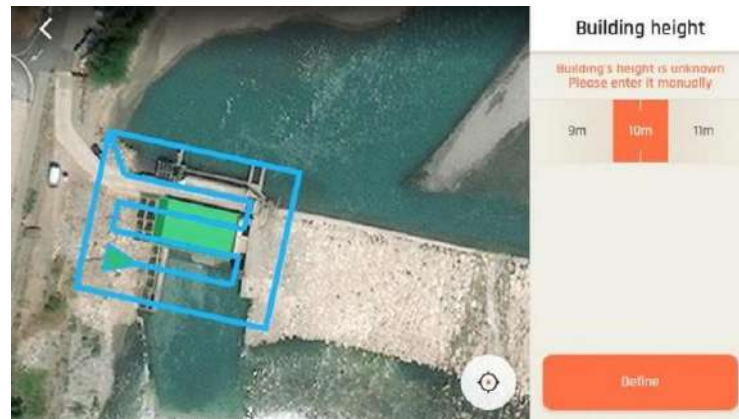

FreeFlight 7 1-Click Photogrammetry

NOTE: If the mission starting point is 50km away, or further, an alert message appears: **First waypoint too far away.**

PIX4D suite compatibility

ANAFI Ai is compatible with the PIX4D software suite, including Pix4Dmapper, Pix4Dinspect, Pix4Dmatic, and Pix4Dcloud. To learn more on how to optimize the processing of the images, please read [PIX4D SOFTWARE TUNING FOR ANAFI Ai](#) documentation.

Missions: Flight Plan

Flight Plan enables you to fully prepare and configure your flights and filming sessions.

ANAFI Ai can support AMSL altitude (Above Mean Sea Level), which allows the drone to use a reference point to measure the environment more precisely.

Tap the **MISSIONS** icon in the bottom-left corner of the FreeFlight 7 HUD to access **Missions** options.

Tap  **Flight Plan** to select this mission. The map of your surroundings opens full screen. If you are not connected to ANAFI Ai, the minimized live view is black.

Tap **New Flight Plan**.

Alternatively, tap Projects on the FreeFlight 7 home screen. Ensure that the **Flight Plan** tab is selected, then tap **New**.

In both scenarios, the Flight Plan project screen opens. Edit the **PROJECT NAME** and tap **Done** to continue to the flight plan.

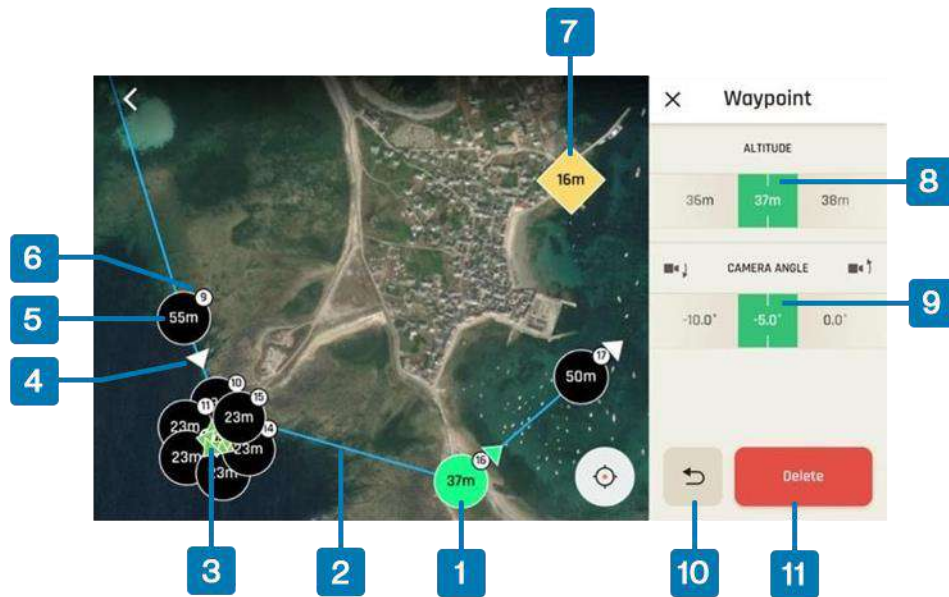

- | | |
|--------------------------------|--------------------------------|
| 1. Currently selected waypoint | 7. Point of Interest (POI) 2 |
| 2. Flight path segment | 8. ALTITUDE slider |
| 3. Waypoints linked to POI 1 | 9. CAMERA SLIDER slider |
| 4. Waypoint camera direction | 10. Delete |
| 5. Waypoint altitude | 11. Undo |
| 6. Waypoint number | |

NOTE: In the screenshot above, POI 1 is obstructed by the linked waypoints.

Choose the location of your initial waypoint, ideally, very close to your intended take-off point. Tap the screen to create the waypoint. The waypoint appears as a green circle. The white figure in the center represents the drone altitude, and the green arrow represents the camera direction.

Change the direction of the ANAFI Ai's camera by pressing and holding on the green arrow. Rotate the arrow to the desired camera direction.

Tap the map to create more waypoints. By default, the new WP is set at the same altitude and camera angle as the previous WP. The camera points in the direction of the flight which brought the drone to the new WP.

Tap the flight path segment between 2 waypoints to activate the Segment interface. You can modify ANAFI Ai's speed for any flight segment (from 0.5 m/s to 12 m/s by 0.5 m/s increments – default value: 5 m/s).

Tap the **+ plus** on the middle of the segment to create a new WP there. By default, the altitude of the new WP considers flight level change between the previous WP and the next WP.

To change the height of an individual waypoint, tap the desired waypoint. Drag the slider on the right of the screen to modify the altitude. In the example above, ANAFI Ai climbs from 37 meters at the currently selected waypoint to 50 meters for the following waypoint.

To change ANAFI Ai's camera angle at a given waypoint, tap the desired waypoint. Drag the slider on the right of the screen to modify the camera angle.

To create a Point of Interest (POI), press and hold on the screen.

The POI appears as a square diamond. The white figure in the center represents the POI altitude. Drag the slider on the right of the screen to modify the altitude.

When you select a POI you can link the waypoints to the POI. Tap a waypoint to link it to the POI.

When you link a waypoint to a POI, the waypoint arrow rotates toward the POI, and the camera angle changes automatically.

NOTE: POIs are color coded. Each POI you create is a different color from the previous. When you link a waypoint to a POI, the waypoint arrow changes color to the corresponding POI color.

To unlink a waypoint from a POI, tap the POI, then tap the waypoint that you want to unlink.

You can modify waypoints and POIs at any time. Tap the waypoint or POI to change the height, and drag the icon to change the location.

To remove a waypoint or a POI, press and hold on the icon, then tap **Delete**.

Flight Plans can take any shape or form, and the last WP does not have to be close to the take-off area. You can start and finish a Flight Plan in different locations.

However, if you want to land away from your take-off area, select **No Final RTH** from the Flight Parameters. Refer to the "[Missions: Flight Plan / Flight Parameters](#)" section for more information.

Image parameters

The Flight Plan is complete. You can now set the Image parameters.

Tap **IMAGE PARAMETERS** > to open the corresponding interface. The following table shows the image parameters, with the default values in bold:

Flight Plan IMAGE PARAMETERS

| | |
|---------------------|---|
| Video: | |
| Resolution : | 4K or 1080p |
| Framerate | 30 fps (24 to 30 fps for 4K / 24 to 60 fps for 1080p) |
| Exposure | -3.0 EV to +3.0 EV (DV: 0.0 EV) |
| White Balance | Auto / Sunny / Cloudy |
| Timelapse: | |
| Duration | 1 s, 2 s , 4 s, 10 s, 30 s or 60 s intervals between shots |
| Resolution | 12 MP / 48 MP |
| Exposure | -3.0 EV to +3.0 EV (DV: 0.0 EV) |
| White Balance | Auto / Sunny / Cloudy |
| GPS lapse: | |
| Distance | 0.5 m, 1 m, 2 m, 5 m, 10 m , 20 m, 50 m, 100 m, or 200 m between shots |
| Resolution | 12 MP / 48 MP |
| Exposure | -3.0 EV to +3.0 EV (DV: 0.0 EV) |
| White Balance | Auto / Sunny / Cloudy |

Tap **X** to close Image parameters and confirm your settings.

NOTE: Zoom is not available during Flight Plan execution when the Flight Plan Mode is **Timelapse** or **GPSLapse**.

Flight parameters

Tap **FLIGHT PARAMETERS** > to open the corresponding interface. 4 flight parameters determine the behavior of ANAFI Ai during a Flight Plan. The following table shows the flight parameters, with the default values in bold:

| | |
|-------------------------|-----------------|
| Obstacle Avoidance | Yes / No |
| Progressive Orientation | Yes / No |
| Final RTH | Yes / No |
| RTH on data link loss | Yes / No |
| Custom RTH | Yes / No |

Tap **X** to close Flight parameters and confirm your settings.

Tap **Done** to save your Flight Plan.

Start your Flight Plan

Close FreeFlight 7, go to your take-off area, set up ANAFI Ai for the flight with your Parrot Skycontroller 4 and your device.

Tap the **MISSIONS** icon in the bottom-left corner of the HUD of FreeFlight 7 to access missions options.

Tap **Flight Plan** to select this mission. The previous plan you programmed appears.

Tap the green ► **Play** (arrow) button from the right of the Flight Plan interface to launch the flight. ANAFI Ai takes off, flies to the first WP and begins the mission.

You can interrupt a flight plan at any time by either stopping or pausing the flight plan.

To stop a flight plan, tap ■ **STOP** (red square). When you finish exploring or taking Panoramas and you are ready to resume the Flight Plan, tap ► **Play** to start again from the latest waypoint ANAFI Ai has passed.

To pause a flight plan, reclaim the commands of the drone during the flight plan. Press **RESUME** to resume the Flight Plan where it paused.

WARNING: monitor every Flight Plan with extreme care. Always verify the drone's route is safe, and clear of obstacles. Always maintain visual contact with ANAFI Ai, and always be ready to stop the Flight Plan (tap the ■ **STOP** box of the HUD or reclaim commands of the drone) in case of danger or unexpected obstacles.

NOTE: If the mission starting point is 50km away, or further, an alert message appears: **First waypoint too far away**.

NOTE: If the FreeFlight 7 device loses internet connection during the mission, the map may not be visible depending on the basemap tiles stored in the cache. However, the drone's path remains visible on the app.

Import

To import a MAVlink file directly in FreeFlight 7, follow the next steps:

1. Send the file to your email address.
2. Open the email with Outlook on your iOS device.
3. Tap on the file.
4. Click on the **share** button.
5. Click on **share with**, and choose FreeFlight 7 App.

FreeFlight 7 opens directly on the Flight Plan interface and loads the MAVlink file.

NOTE: An imported flight plan cannot be edited.

Missions: Cameraman

The Cameraman mission enables you to keep an object or a subject in the center of your frame, while you pilot ANAFI Ai around it/him/her.

Frame the object or subject you want to film and fly around.

Tap the **MISSIONS** icon in the bottom-left hand corner of the HUD of FreeFlight 7 to access the missions options.

Tap **Cameraman** to select this mission.

Up to 10 potential targets (people, vehicles, animals, etc.) appear highlighted in yellow:



CAMERAMAN: Potential target selection

Tap a potential target to select it, or draw a rectangle with your finger on the screen of your device, around the object or subject you want ANAFI Ai to follow.

When your target is locked, it appears highlighted in green, as in the next screenshots, where a moving vehicle was selected.

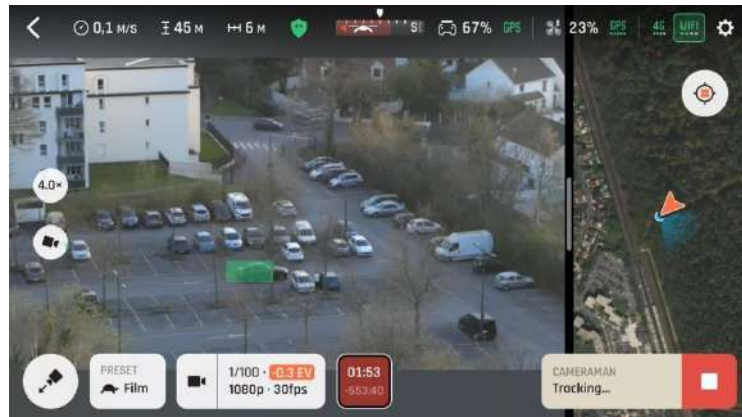

Tracking in progress 1

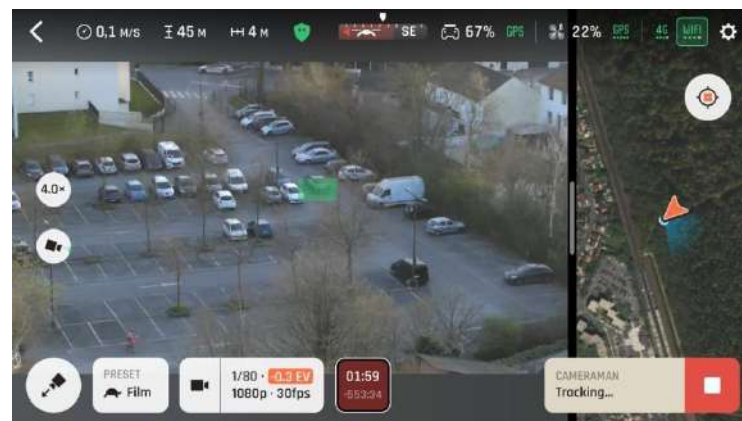

Tracking in progress 2

Fly ANAFI Ai around your target. The drone keeps your target at the center of the frame.

Push the right joystick of the Parrot Skycontroller 4 to the left, ANAFI Ai circles around your target clockwise.

Push the right joystick of the Parrot Skycontroller 4 to the right, ANAFI Ai circles around your target counterclockwise.

When the Cameraman mode is activated, ANAFI Ai manages the gimbal tilt to keep the target in the frame. Therefore, the left trigger of the Parrot Skycontroller 4 is deactivated in this mode. However, you can still control the zoom, with the right trigger.

When you release the commands in the Cameraman mode, ANAFI Ai hovers and rotates to continue following the target.

To end the following of your target, tap **STOP** (white square on red background) in the bottom right-hand corner of the HUD.

When no target is selected, or when the following of the target has been ended by the pilot, ANAFI Ai's behavior is similar to that of the Piloting mission.

Activate and monitor the Cameraman mode with care. Always check your flight plan and the trajectory of your subject are clear from obstacles and safe, always retain visual contact with ANAFI Ai, and always be ready to stop the following (tap the **STOP** button on your HUD) in case a danger or any sort of unexpected obstacle arises.

Missions: Vehicle

The Vehicle mission enables authorized pilots to take off and control their drone from a moving vehicle (for example a pickup truck or a boat), then to land it safely back on the moving vehicle (up to a 25 km/h or 17.5 mph speed).

Vehicle missions consume more battery power. Increase the safety margins on your battery readings. If you normally land with 20% battery power remaining, aim for 30 %.

Set up ANAFI Ai for take-off in the direction of motion of the moving platform.

To activate this feature, you must have a double GPS fix (drone and device).

Parrot recommends initiating Vehicle mission flights from a distinctive black and white take-off/landing platform such as the Parrot landing pad. You can download and print the Parrot landing pad [here](#). The minimum size is 70cm x 70cm.

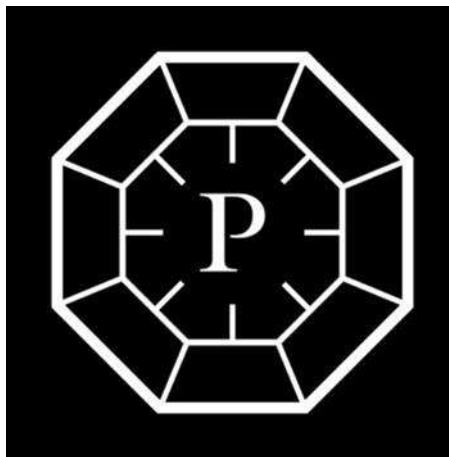

Landing pad

From take-off, ANAFI Ai synchronizes its speed and trajectory to that of the vehicle, tracking and following it. The pilot retains control of the flight of the drone, relative to the vehicle's reference.

The drone follows the vehicle by default, even when the command is activated. However, the pilot retains control of the precise trajectory of ANAFI Ai, its direction, and the framing of the camera.

When you follow a vehicle, a link appears between your drone and the vehicle to symbolize the **tracking mission**.

During a Vehicle mission, activating the RTH command initiates a return sequence toward the vehicle (**Returning to vehicle**). The following sections describe all phases of Vehicle missions.

Vehicle take-off

1. Set up ANAFI Ai in the direction of the movement of the vehicle.
2. Check your operating area provides GPS synchronization for both the drone and the controller.
3. Stabilize the speed of the vehicle to under 25 km/h (15.5 mph).

4. Activate the Vehicle mission from the **MISSIONS** icon on the bottom left of the FreeFlight 7 screen.
5. Stabilize the direction of the vehicle. If possible, take off from a straight stretch of a road.
6. Tap  **Take-off** to make ANAFI Ai take off. It stabilizes 5m above its take-off point and then tracks and follows the vehicle.



All green for take-off



Take-off complete, RTH position set

7. From this point onwards, you cannot exit the Vehicle mission before you land the drone. For more information, refer to the next sections of this guide for additional details.
8. You have control over the trajectory and framing of the drone, relative to the referential of the motion of the vehicle in which you travel with the Skycontroller 4.

Vehicle navigation safety

Always activate and monitor Vehicle missions with great care. It is easy to get disoriented when controlling a moving vector from another moving vector.

NOTE: When the tracking is active, the default behavior of ANAFI Ai is to track and follow the vehicle. It does not hover without commands from the pilot.

Always ensure that your flight plan and the trajectory of your vehicle are clear from obstacles and is safe. Always retain visual contact with ANAFI Ai, and always be ready to suspend the tracking and make the drone hover (tap the square  **STOP** button on the bottom right-hand corner of the FreeFlight 7 screen, as in the screenshot below).



Tracking in progress, no command from the pilot: ANAFI Ai is travelling as the same speed as the vehicle



Tracking suspended, no command from the pilot. ANAFI Ai hovers

When the pilot suspends tracking during a Vehicle mission, the behavior of the drone is the same as the Piloting mission.

Tap the green ► **PLAY** button, as seen in the previous screenshot, to restore tracking.

Returning to vehicle

The Returning to vehicle (RTV) feature returns ANAFI Ai to the vehicle from which it took off, and which hosts the Skycontroller 4.

Smart rules associated with RTH features of ANAFI Ai (low battery, ecosystem link loss) are also valid for RTV.

When an RTV is activated:

1. ANAFI Ai accelerates toward the tracked vehicle, moving upward to reach the minimum RTH altitude, if it was flying below it. Refer to the "[Settings / Advanced / RTH](#)" section for more information.



Returning to vehicle activated

2. ANAFI Ai catches up with the vehicle based on its GPS position, then begins to descend to scan for it visually. When the drone reaches 30m above the vehicle, the drone's main camera turns to the ground to locate it.

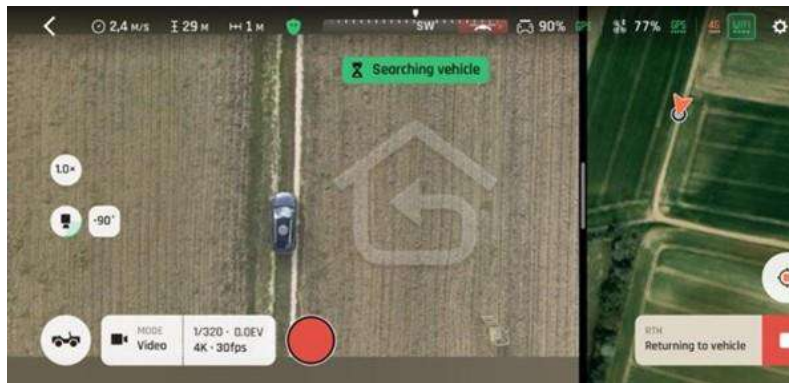

Searching vehicle

3. When the vehicle is identified, ANAFI Ai stays synchronized to its route and speed, and descends to the selected hovering height, or the **landing zone search** height, if you have selected the **Landing** ending from the Advanced RTH settings.



Vehicle found: descent to hover altitude is about to begin

Vehicle landing safety

WARNING: Landing a drone on a moving vehicle is a technical gesture, which requires training and focus. Landing is always one of the most sensitive parts of a flight and performing it in motion makes it even more crucial.

Always monitor each stage of the **Returning to vehicle** and Landing sequences carefully, even if select the **Landing** ending for Vehicle missions. Always be ready to reclaim control of the drone at any stage of the flight.

Vehicle missions consume more battery power. Increase the safety margins on your battery readings. If you normally land with 20% battery power remaining, aim for 30 %.

The landing sequence of a Vehicle mission implies the activation of a **landing zone search** by ANAFI Ai. This search can:

- occur automatically after an RTV, if you select the **Landing** ending from the Advanced RTH settings;
- occur by pilot action on the  **Take-off/Land** button when the drone is at a maximum distance of 30m from the vehicle. The drone descends to 8m high before starting the search.

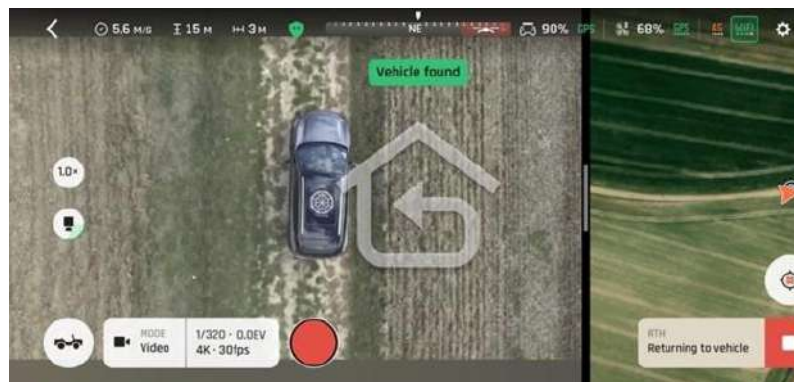

Landing sequence initiated - Searching landing zone

- If the vehicle is moving and the landing zone cannot be acquired after 8 seconds, the drone automatically lands at a reduced speed. FreeFlight 7 prompts you to adjust the drone's position.
- If the vehicle is stopped, the drone continues to descend while searching for the landing zone. If the landing zone cannot be acquired, FreeFlight 7 prompts you to adjust the drone's position and the drone lands while tracking the vehicle position.

When the drone acquires the landing zone, the top center of the screen displays a **Precise landing** notification.

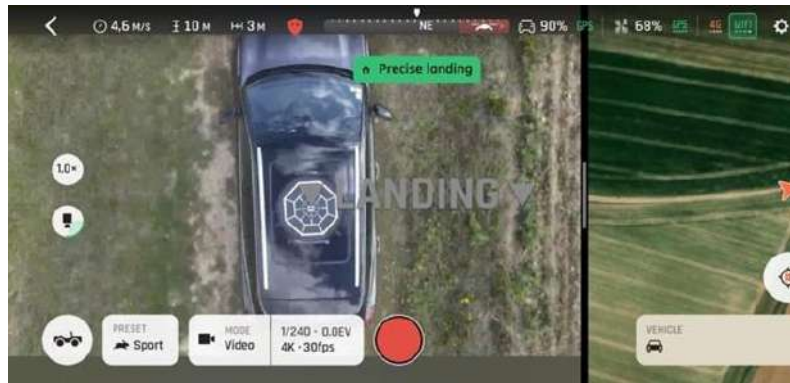

Precise landing activated

This is ANAFI Ai’s final approach signal. From there it descends steadily, around 1 m/s, from 8 m height to its landing point.

- Stabilize the direction of your vehicle and maintain the vehicle at a constant speed below 25 km/h (15.5 mph).

Up until ANAFI Ai has safely landed, you can abort the Vehicle landing by reclaiming the thrust commands and making the drone climb, if any issue arises (for example, GPS loss, bump on the road, wind gusts, water too choppy, etc.).

- Always monitor and control Vehicle mission landings with care. Do not hesitate to briefly stop the vehicle to perform a safer landing if you feel unsure about motion landing conditions.

NOTE: The vehicle mission landing sequence is less effective when there is a strong contrast between the vehicle and the vehicle surroundings, particularly when there is strong sun exposure. For example, on a sunny day, ANAFI Ai may not be able to identify the vehicle and the landing zone, if:

- The vehicle is a white boat on a dark lake.
- The vehicle is a black car on ground covered in snow.

To reduce the contrast, add elements (paint, boards, non-reflective paper, etc.) to the vehicle so that the landing area and the vehicle are not under/overexposed. Parrot recommends initiating Vehicle mission flights from a distinctive black and white take-off/landing platform such as the Parrot landing pad. You can download and print the Parrot landing pad [here](#).

Missions: Touch & Fly

Touch & Fly: Waypoint

The Waypoint (**WP**) **Touch & Fly** mode enables you to fly ANAFI Ai to any point on the map. Tap **Touch & Fly** from the **PILOTING MODE** box menu. The map of your surroundings opens full screen. The live image captured by ANAFI Ai is minimized in the top right-hand corner of the screen.

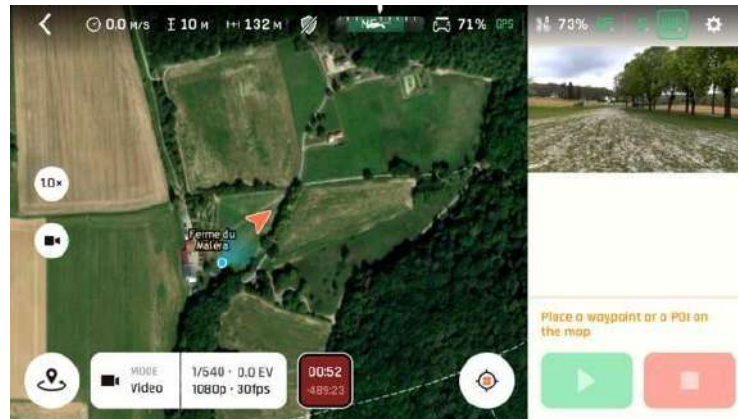

Touch & Fly interface

Single tap a point on the map to select a destination for ANAFI Ai. The drone turns toward this point, which is marked as a black circle with a green border. Use the slider on the right of the screen to set the drone's **WP ALTITUDE**.



Touch & Fly WP configuration

Tap the green **Play** button on the bottom right of the interface to send ANAFI Ai toward its defined WP (position and height).

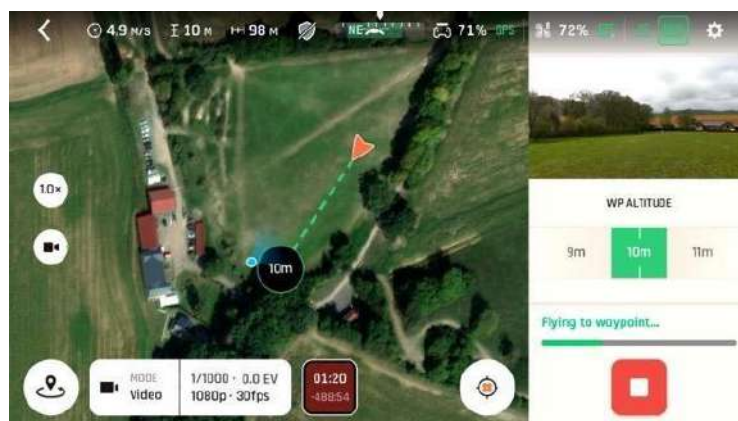

Touch & Fly - Drone flying toward WP

When the waypoint is set on the map, you can tap the live image window to display it full screen. The waypoint will be visible on its center.

You can then tap on the live image or drag and drop the waypoint to set its new position. The new waypoint location is set on a cylinder with, as a center the drone, and as a radius the distance between the drone and the last waypoint.

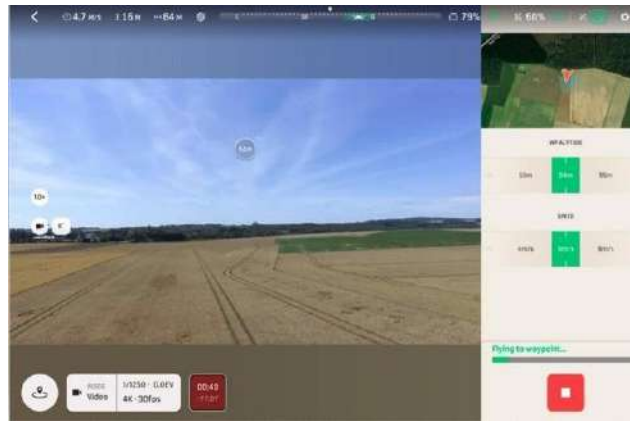

Touch & fly - WP on the live image

Touch & Fly: POI

The Point of Interest (POI) **Touch & Fly** mode enables you to fly ANAFI Ai around any point on the map, keeping this particular point at the center of the map. Tap **Touch & Fly** from the **PILOTING MODE** box. The map of your surroundings opens full screen. The live image captured by ANAFI Ai is minimized in the top right-hand corner of your screen.

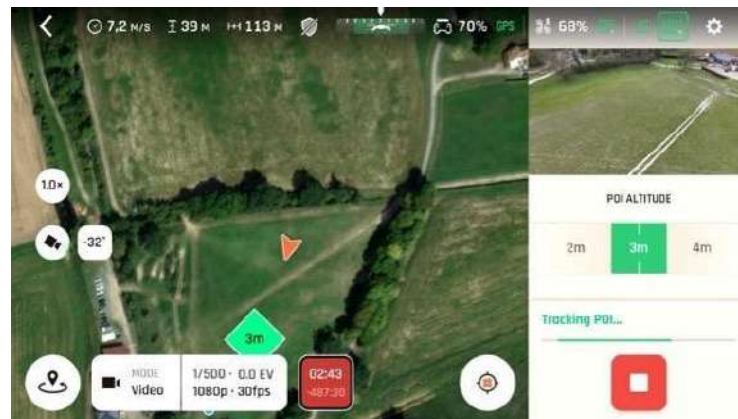

Touch & fly - Tracking POI

Long press a point on the map to create a POI for ANAFI Ai. This point is marked as a green square with a white border. Use the slider on the right of the screen to set the **POI ALTITUDE**.

When the POI is set on the map, you can tap the live image window to display it full screen. The POI will be visible on its center.

You can then tap on the live image or drag and drop the POI to set its new position. The new POI location is set on a horizontal plane which has the same height of the previous POI.



Touch & Fly - POI on the live video

Fly ANAFI Ai around your POI. The drone keeps the POI at the center of the frame.

Push the right joystick of the Parrot Skycontroller 4 to the left, ANAFI Ai circles around the POI clockwise.

Push the right joystick of the Parrot Skycontroller 4 to the right, ANAFI Ai circles around the POI counterclockwise.

When the Touch & Fly POI mode is activated, ANAFI Ai manages the gimbal tilt to keep the POI in the frame. Therefore, the left trigger of the Parrot Skycontroller 4 is deactivated in this mode. However, you can still control the zoom, with the right trigger.

When you release the commands in **Touch & Fly POI** mode, ANAFI Ai hovers and keeps the POI at the center of the frame. To end the following of the POI, tap the white square on red background (**STOP** button) in the bottom right-hand corner of the HUD.

Flight logs and projects management

If you have not activated the zero data mode of the ANAFI Ai ecosystem, FreeFlight 7 keeps your flight logs and lets you easily manage your projects (Flight Plans and Photogrammetry), from the homescreen.

This section describes the corresponding interfaces.

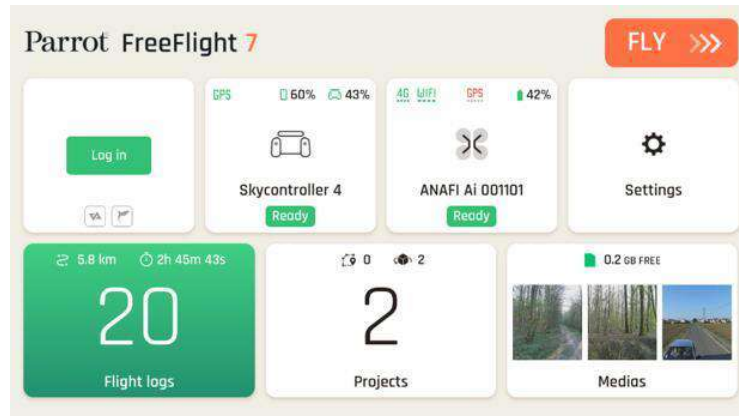

FreeFlight 7 homescreen

Flight logs

The **Flight logs** tile of the homescreen displays the number of recorded flights, the corresponding distance flown, and the corresponding flight time.

Tap the tile to access **Flight logs**.

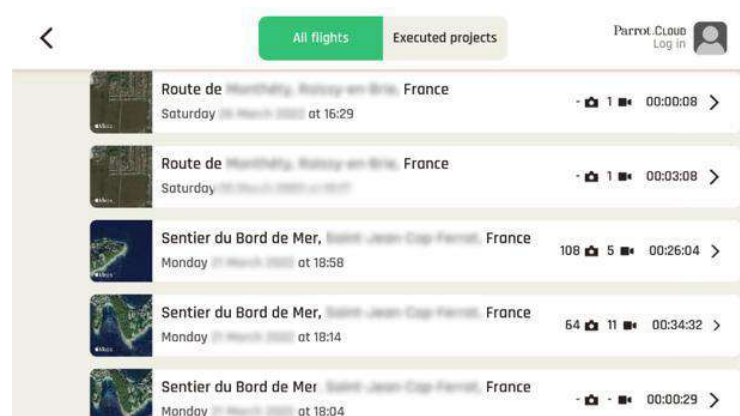

All flights list

From this interface, you can toggle between 2 tabs: **All flights** and **Executed projects**.

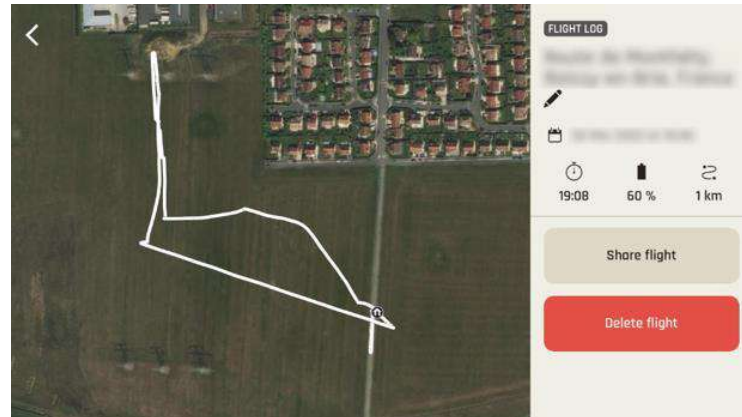

Individual FLIGHT LOG

Tap a flight to open it. From this screen, you can:

- Tap  **Edit** to edit the name of the flight,
- Check the time, date, and details of the flight,
- Tap **Share flight** to share through all iOS sharing options,
- Tap **Delete flight** to delete individual flights. You must confirm your choice to delete.

On the left-hand side, you can slide, zoom in or out, and navigate in the map of the surrounding area of your flight.

Tap **< back** to return to the Flights list.

Projects

The **Projects** tile of the homescreen displays the total number of projects. You can toggle between 2 tabs: the **Flight Plan** tab, to show details of the number of recorded flight plans, and the **Photogrammetry** tab, to show the number of recorded photogrammetry missions.

Tap the **Projects** tile to access projects.

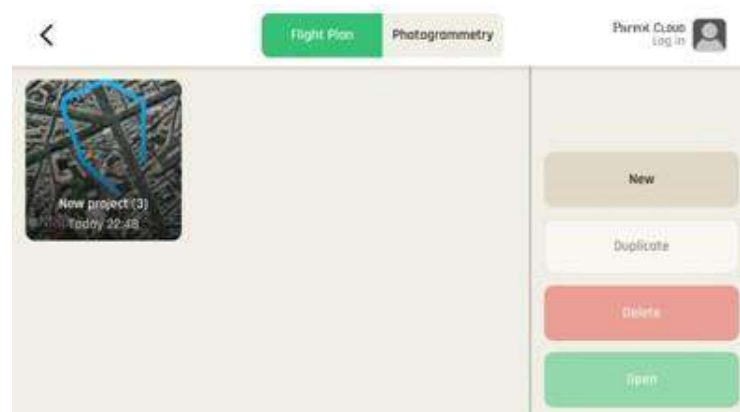

Flight Plan projects

The app displays saved **Flight Plans** first. If no **Flight Plan** has been programmed, the list is empty the first time you access the interface.

Tap **New** to create a new project in the **Flight Plan** mission interface.

Tap a project to select it, the following options appear or activate:

- Tap  **Edit** to edit the project name;
- **Duplicate** the project;
- **Delete** the project;
- **Open** the project (you can double tap projects directly from the list to open them in the Flight Plan mission interface).

Tap the **Photogrammetry** tab to access the photogrammetry projects.



Photogrammetry projects

Tap **New** to create a new project in the Photogrammetry mission interface.

Tap a project to select it, the following options appear or activate:

- Tap  **Edit** to edit the project name;
- **Duplicate** the project;
- **Delete** the project;
- **Open** the project (you can double tap projects directly from the list to open them in the Photogrammetry mission interface).

Tap **< back** to return to the homescreen.

Maintenance and Troubleshooting

This section describes basic procedures to maintain your drone and troubleshoot most issues you may encounter using ANAFI Ai. In addition, drone and controller reset procedures can be useful before a change of operator or operating structure.

Changing propeller blades

Propeller blades are delicate pieces of equipment and are instrumental for flight integrity. Even minor contacts with external elements (walls, tree branches, etc.) can damage their structure. Damage is not necessarily visible.

As a safeguard measure, ANAFI Ai is programmed to cut its motors instantly in case of impact to one of its propeller blades. Always control your drone carefully.

TIP: Replace propeller blades if they sustain even minor contacts with the environment. Replace propeller blades every 50 flight hours, as part of scheduled maintenance.

ANAFI Ai propeller blades can be replaced, instantly without tools. Follow this procedure to replace a propeller blade:

1. Unfold the arm that supports the blades which require replacement.
2. Hold the motor (round rotating part) of the propeller between your left thumb and index finger.
3. Unfold the blades.
4. Pinch the propeller hub (between the blades) with your right thumb and index.

A. blades: unscrew used/damaged A blades (Front left & rear right) counterclockwise and screw new ones clockwise.

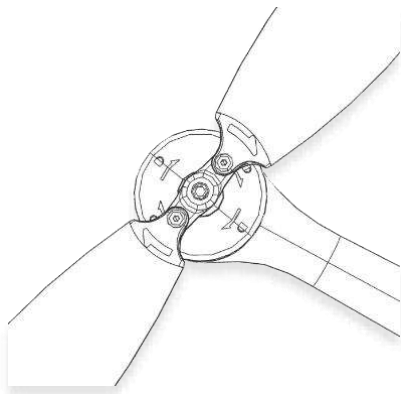

B. blades: unscrew used/damaged B blades (Rear left & front right) clockwise and screw new ones counterclockwise.

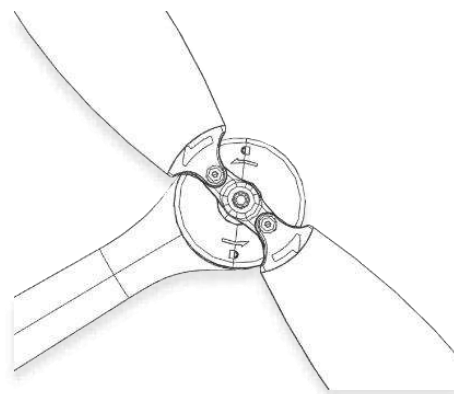

Ensure that your blades respect the following diagram before setting up ANAFI Ai for its next flight.

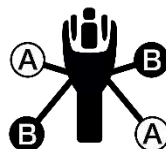

You can purchase propeller blades and ANAFI Ai smart batteries separately. Find an ANAFI Ai spare parts reseller [here](#).

Rebooting all systems

When the ecosystem does not perform as expected, the first procedure is to power off and reboot all

elements of the ecosystem. Rebooting all systems can solve connectivity issues (black screen, white noise, etc.):

1. Press **Power** to power off ANAFI Ai.
2. Close the FreeFlight 7 application on your device.
3. Reboot your Skycontroller 4.
4. Press **Power** to power on ANAFI Ai.
5. Wait for synchronization between Skycontroller 4 and ANAFI Ai: check that the left trigger of the Skycontroller 4 activates the drone's gimbal to ensure the synchronization is complete.

Reinstalling FreeFlight 7

If you must delete and reinstall FreeFlight 7 later, ensure that you back up all your device FreeFlight 7 media, as media may be deleted along with the application.

ANAFI Ai drone hard reset

Resetting ANAFI Ai reverts the drone back to its latest firmware update. It cleans all media, logs and credentials from the drone. For this reason, ensure that you back up all your **Drone memory** FreeFlight 7 media before resetting ANAFI Ai.

To reset ANAFI Ai, press and hold the drone's **Power** button for approximately 10 seconds, until one of the LED flashes in red, then release the button immediately.

The drone reboots. The reset is successful.

The same procedure can be performed through the **Reset** button of ANAFI Ai's page, in FreeFlight 7.

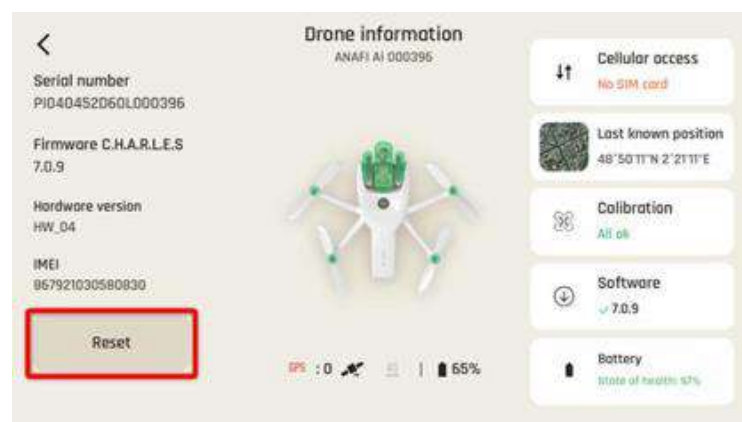

FreeFlight 7 - Position of the reset button on the ANAFI Ai page

Resetting the Skycontroller 4

Resetting the Skycontroller 4 reverts the controller back to its latest firmware update. It cleans all logs and credentials and restores the original ecosystem's Wi-Fi SSID and password.

To reset the Skycontroller 4, ensure that it is not connected to any drone, or the drone will initiate a take-off sequence.

Press and hold the controller's **Take-off/Land**, **Optics reset**, and **Media recording** buttons for 15 seconds, then release the 3 buttons.

NOTE: The LED starts flashing after 10 seconds, but you must hold the buttons for 5 more seconds.

The Skycontroller 4 reboots. The reset is successful.

The same procedure can be performed safely, even with a drone connected, through the **Reset** button of the Skycontroller 4 page, in FreeFlight 7.

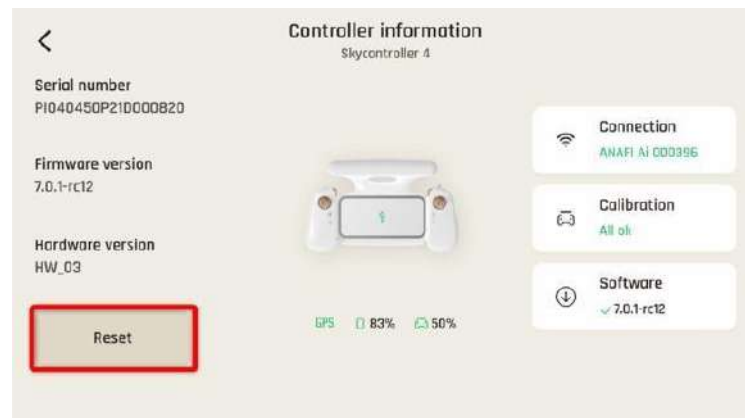

FreeFlight 7 - **Reset** button on the Skycontroller 4 page

WARNING: When the Skycontroller 4 reboots, the connection between the drone and controller is lost.

ANAFI Ai's smart battery hard reset

A hard reset of ANAFI Ai's battery can correct battery issues. Parrot recommends a battery hard reset whenever the battery's behavior is unexpected.

You must reset your battery if:

- the battery behavior is not consistent with the information in the *"Smart LiPo Battery"* chapter,
- the battery does not power on ANAFI Ai,

Follow this procedure to hard reset the smart battery:



1. Connect the smart battery to a power source.
2. Regardless of the battery's behavior, press and hold its power button for 15 seconds.
3. Release the  **Power** button.

The battery's LEDs flash quickly, one after the other, alternating green and red. The reset is successful.

TIP: Replace smart batteries after 300 charge/discharge cycles to ensure lasting performance.

Recover ANAFI Ai

In the event of a hazardous situation, follow this procedure:

1. Press  **RTH** on the Skycontroller 4 to cause the drone to return to its home position.
2. If the drone does not return, attempt to initiate an automatic landing by pressing the  **Take-off/Land** button on the Skycontroller 4.
3. Try to locate the ANAFI Ai position.
4. Ensure that this event does not cause a subsequent hazardous situation based on its last known position.

WARNING: If there is a reasonable expectation that the loss of control will cause injury to a person, contact the emergency services. Hazardous circumstances may result in a situation where normal use of ANAFI Ai is not respected. Read and respect the operational requirements described in the checklist appendix 1.

4G connectivity issues

Causes of 4G connectivity issues can include:

- There is no SIM card in the drone.
- You did not enter the SIM card code of the drone.
- Drone's 4G connectivity is not activated.
- Your mobile has no internet access.
- The 4G connection is not established.

In these cases, FreeFlight 7 connectivity interface informs the origin of the issue.

Otherwise, the interface displays the **ask for support** option.

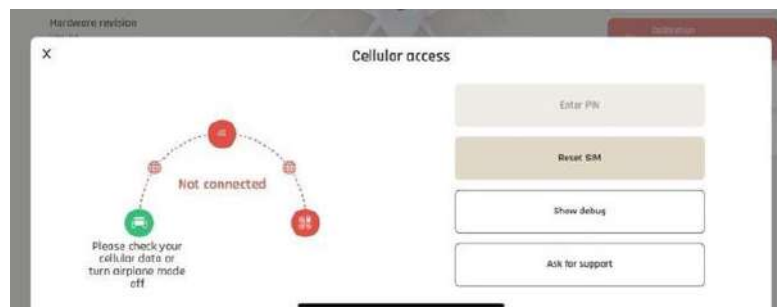

Connection error

If you tap **Ask for support**, a dialogue box appears. You must enter the following information:

- **Smartphone SIM card operator name**
- **Phone number or email**
- **Country**

For the following fields, choose between the 2 options:

- **Internet connection used on your device**
- **Did you already manage to connect your drone in 4G?**

When you tap **Send**, you must accept to share your data with Parrot.

The App then helps you to create a ticket for our technical team. Parrot will contact you to solve your problem.



Ask for support interface

Drone end of service life

Refer to the flight safety guide manual provided inside the packaging to find complementary information on how to recycle this product.

The propeller blades and the carry box are made of plastic, they can be disposed of in a recycle bin.

All the electronic devices (ANAFI Ai, Skycontroller 4, smart battery) must be returned to a collection point (e.g. stores, recycling center) to be recycled. It is indicated by the following logos:



Appendix 1: Operational Checklist

Update & calibration

| | |
|---|---------------------------|
| Device | SYSTEMATICALLY UP TO DATE |
| FreeFlight 7 | SYSTEMATICALLY UP TO DATE |
| Skycontroller 4 | SYSTEMATICALLY UP TO DATE |
| ANAFI Ai | SYSTEMATICALLY UP TO DATE |
| Magneto calibration | OK |
| Skycontroller 4 calibration | OK |
| Gimbal calibration | OK |
| Horizon calibration (exceptional) | OK |
| Obstacle avoidance calibration | OK |

IMPORTANT: Parrot strongly recommends that you regularly refer to the [Release Notes ANAFI Ai](#) available on the Parrot website, to ensure that you have the latest versions of the drone and controller firmware, and FreeFlight 7 App.

Skycontroller 4 & ANAFI Ai OFF

| | |
|---|--|
| Arms | unfolded, locked |
| Arms mechanical lash | NONE |
| Lens cap | OFF |
| Check drone and gimbal | OK |
| Check propellers | intact, free, fully screwed on. |
| Check Skycontroller 4 | OK, 100% charged. |
| Check terminal to Skycontroller 4 cable | OK |
| ANAFI Ai battery | intact, locked in place, 100% charged. |
| Device battery | OK, charged. |
| MicroSD card | inserted, with sufficient memory. |

Skycontroller 4 & ANAFI Ai ON

| | |
|-------------------------|--------------------------------------|
| Skycontroller 4 | flashing light to dark blue LED |
| ANAFI Ai | ON, gimbal OK |
| Device | ON, Wi-Fi OFF |
| Device / C2 link | FreeFlight 7 launched, image feed OK |
| RTH parameters | set |
| Max altitude | set |
| Max distance | set |
| Image setting | OK |
| Global reactivity | set |
| Vertical speed | set |
| Rotation speed | set |

Before Take-off

| | |
|---------------------|--------------------|
| Device GPS | signal Red / Green |
| Flight mode | MANUAL |
| Weather | checked and OK |
| Take-off Zone | clear |

Drone status checked
 Take-off/Land command Take Off

After Take-off

Precise Home Set OK
 Check flight commands OK
 Check gimbal OK
 Video feed OK
 Video latency OK
 Drone status Check

Before landing

Flight mode MANUAL
 Weather OK
 Landing Zone Clear
 Drone status Check
 Take-off/Land command Land

After landing

Check engines off OFF
 Drone status Check
 Arms mechanical lash NONE
 Skycontroller 4 OFF, stored away.
 Check drone/gimbal/propellers OK
 Lens cap ON
 ANAFI Ai battery Off
 ANAFI Ai arms Stored away.
 ANAFI Ai drone Stored away.
 MicroSD card Stored away.
 Cables Stored away.